

SDC104R SERIES~ SMD Shielded Power Inductors



PART NUMBERING SYSTEM

SDC	104R	—	151N	—	LF
TYPE	DIMENSIONS		INDUCTANCE		LEAD FREE

SHAPES AND DIMENSIONS

UNIT : mm

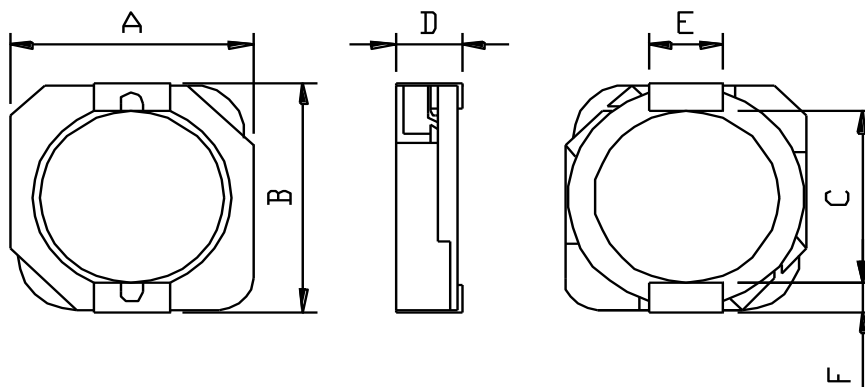

A=10.3 max. B=10.4 max. C=7.70 REF D=4.0 max. E=3.0 REF F=1.2 REF

RECOMMENDED PATTERNS

UNIT : mm

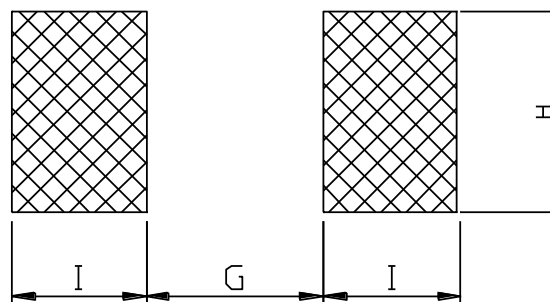

H= 3.20 G= 7.30 I = 1.60 J =1.60

FEATURES

- Low profile (4.0mm max. height) and 10.3mmx10.5mm max. square.
- Magnetically shielded and low DC resistance ..

SDC104R SERIES~ SMD Shielded Power Inductors



ELECTRICAL CHARACTERISTICS :

PART NUMBER	INDUCTANCE (μ H)	DCR (m Ω) (Max.)	Isat (A) (Max.)	Irms (A) (Max.)	TEST FREQ. (f)
SDC104R-1R5N-LF	1.5 \pm 30%	8.1	10.0	6.50	100KHz 1V
SDC104R-2R5N-LF	2.5 \pm 30%	10.5	7.50	6.10	100KHz 1V
SDC104R-3R8N-LF	3.8 \pm 30%	13.0	6.00	5.50	100KHz 1V
SDC104R-5R2N-LF	5.2 \pm 30%	22.0	5.50	5.40	100KHz 1V
SDC104R-7R0N-LF	7.0 \pm 30%	27.0	4.80	4.50	100KHz 1V
SDC104R-100N-LF	10 \pm 30%	35.0	4.40	3.80	100KHz 1V
SDC104R-120N-LF	12 \pm 30%	46.0	3.70	3.40	100KHz 1V
SDC104R-150N-LF	15 \pm 30%	50.0	3.60	3.10	100KHz 1V
SDC104R-180N-LF	18 \pm 30%	69.0	3.10	2.60	100KHz 1V
SDC104R-220N-LF	22 \pm 30%	73.0	2.90	2.50	100KHz 1V
SDC104R-270N-LF	27 \pm 30%	88.0	2.60	2.30	100KHz 1V
SDC104R-330N-LF	33 \pm 30%	93.0	2.30	2.20	100KHz 1V
SDC104R-390N-LF	39 \pm 30%	127	2.20	2.00	100KHz 1V
SDC104R-470N-LF	47 \pm 30%	128	2.10	1.90	100KHz 1V
SDC104R-560N-LF	56 \pm 30%	188	1.65	1.50	100KHz 1V
SDC104R-680N-LF	68 \pm 30%	213	1.50	1.42	100KHz 1V
SDC104R-820N-LF	82 \pm 30%	283	1.45	1.30	100KHz 1V
SDC104R-101N-LF	100 \pm 30%	304	1.35	1.25	100KHz 1V
SDC104R-121N-LF	120 \pm 30%	375	1.20	1.08	100KHz 1V
SDC104R-151N-LF	150 \pm 30%	506	1.15	0.85	100KHz 1V
SDC104R-181N-LF	180 \pm 30%	568	1.00	0.75	100KHz 1V
SDC104R-221N-LF	220 \pm 30%	756	0.92	0.70	100KHz 1V
SDC104R-271N-LF	270 \pm 30%	853	0.84	0.55	100KHz 1V
SDC104R-331N-LF	330 \pm 30%	1090	0.70	0.52	100KHz 1V

- Isat : DC current at which the inductance drops 35% (typ) from its value without current.
- Irms: The actual current when temperature of coil becomes $\Delta 40^{\circ}\text{C}$. ($T_a=+25^{\circ}\text{C}$)
- Operating temperature range from -40°C to $+125^{\circ}\text{C}$, Electrical specifications at 25°C .
- **PLATING / SOLDER : TIN-SILVER-COPPER (95.5%/4.0%/0.5%)**

SDC104R SERIES~ SMD Shielded Power Inductors



PACKAGING SPECIFICATION

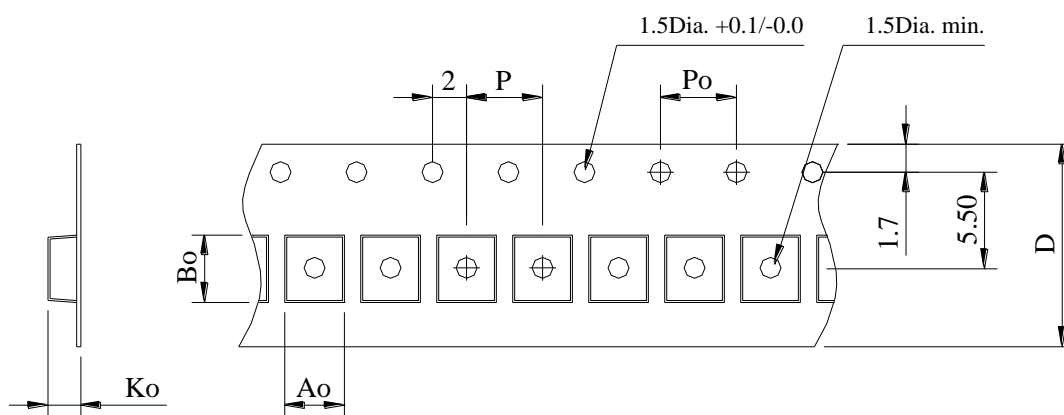

STAYLE	Q' TY (PCS)	DIMENSIONS (m/m)					
		A_o	B_o	K_o	P	P_o	$D\pm 0.3$
13"	1,000	10.4	10.4	4.1	16.0	4.00	24.0