



# SDC5D28 SERIES

## SMD Shielded Power Inductors



RoHS Compliant

### PART NUMBERING SYSTEM

<b>SDC</b>	<b>5 D 2 8</b>	—	<b>2 R 5 N</b>	—	<b>LF</b>
TYPE	DIMENSIONS		INDUCTANCE		LEAD FREE

### SHAPES AND DIMENSIONS

UNIT : mm

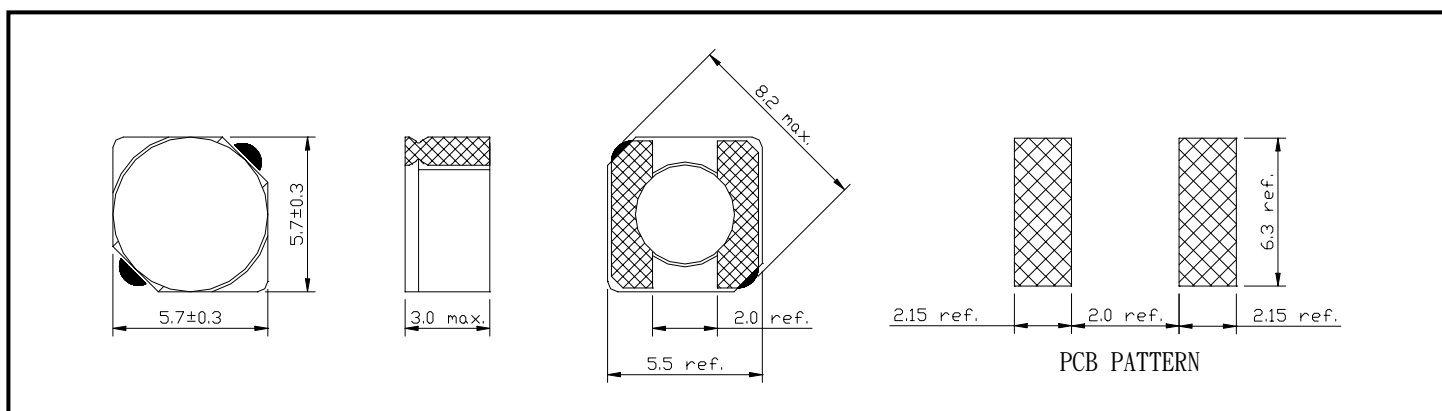

### PACKAGING SPECIFICATION

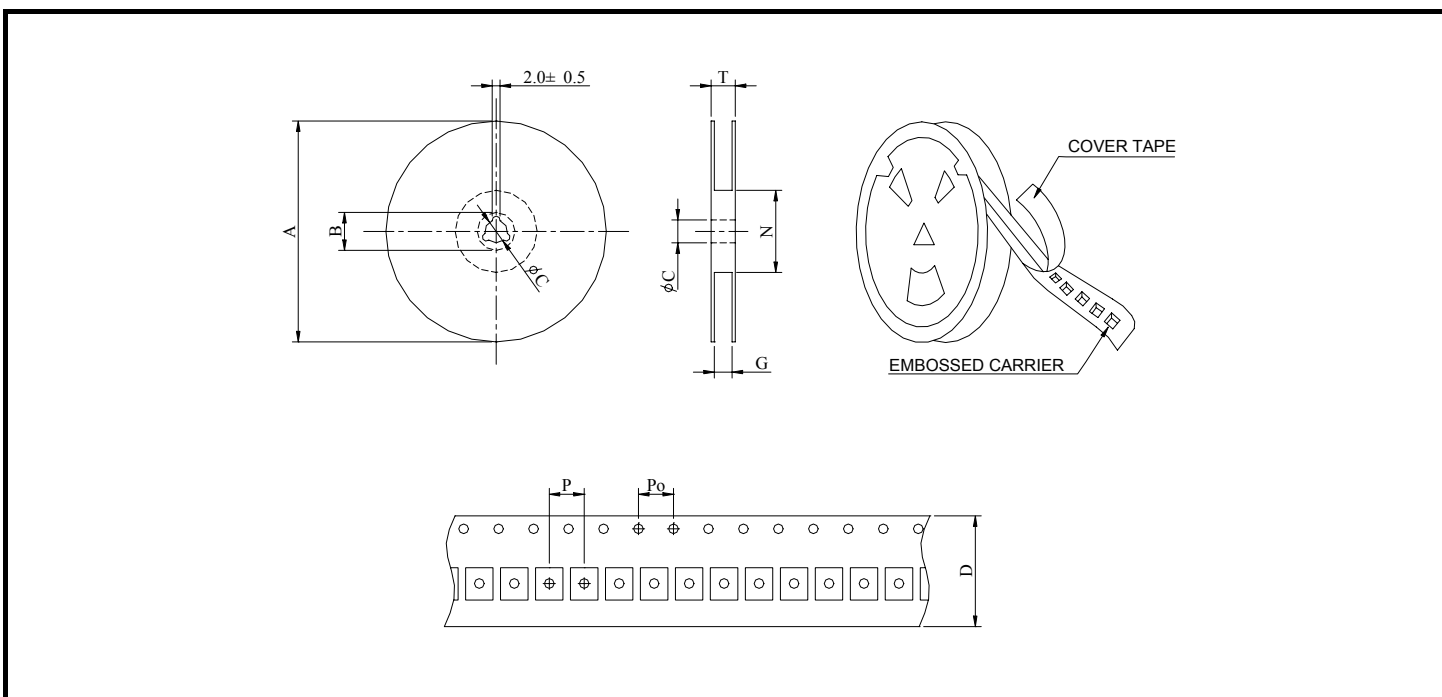

SERIES	STAYLE	Q' TY (PCS)	DIMENSIONS (m/m)								
			A	B $\pm 0.8$	C $\pm 0.5$	D	G $^{+0}$	N $^{-0}$	P	P $_0$	T
SDC5D28	13-16	2000	330	21	13	16	18	50	8	4	22.4



## SDC5D28 SERIES

### SMD Shielded Power Inductors



RoHS Compliant

#### SPECIFICATION TABLE

PART NUMBER	INDUCTANCE ( $\mu$ H)	DCR (m $\Omega$ ) (Max.)	IDC ( A )	TEST FREQ. ( f )
SDC5D28-2R5N-LF	2.5 $\pm$ 30%	18	2.60	10KHz
SDC5D28-3R0N-LF	3.0 $\pm$ 30%	24	2.40	10KHz
SDC5D28-4R2N-LF	4.2 $\pm$ 30%	31	2.20	10KHz
SDC5D28-5R3N-LF	5.3 $\pm$ 30%	38	1.90	10KHz
SDC5D28-6R2N-LF	6.2 $\pm$ 30%	45	1.80	10KHz
SDC5D28-8R2N-LF	8.2 $\pm$ 30%	53	1.60	10KHz
SDC5D28-100N-LF	10 $\pm$ 30%	65	1.30	10KHz
SDC5D28-120N-LF	12 $\pm$ 30%	76	1.20	10KHz
SDC5D28-150N-LF	15 $\pm$ 30%	103	1.10	10KHz
SDC5D28-180N-LF	18 $\pm$ 30%	110	1.00	10KHz
SDC5D28-220M-LF	22 $\pm$ 20%	122	0.90	10KHz
SDC5D28-270M-LF	27 $\pm$ 20%	175	0.85	10KHz
SDC5D28-330M-LF	33 $\pm$ 20%	189	0.75	10KHz
SDC5D28-390M-LF	39 $\pm$ 20%	212	0.70	10KHz
SDC5D28-470M-LF	47 $\pm$ 20%	250	0.62	10KHz
SDC5D28-560M-LF	56 $\pm$ 20%	305	0.58	10KHz
SDC5D28-680M-LF	68 $\pm$ 20%	355	0.52	10KHz
SDC5D28-820M-LF	82 $\pm$ 20%	463	0.46	10KHz
SDC5D28-101M-LF	100 $\pm$ 20%	520	0.42	10KHz

- Isat : DC current at which the inductance drops 35% (typ) from its value without current.
- Irms: The actual current when temperature of coil becomes  $\Delta$ 40°C . ( Ta=+20°C )
- Operating temperature range -40°C to +85°C , Electrical specifications at 20°C.
- Packing : 13" reel, machine-ready ,embossed plastic tape ( 2,000 parts per full reel).