

Polymer PTC Resettable Fuse: KRT Series

Radial Lead Type For Telecom Applications



■ Features

1. RoHS & Halogen-Free (HF) compliant
2. Hold current ratings from 0.08 A to 0.18A
3. High operating voltage rating :100Vdc/250Vdc
4. Resettable for over-current protection
5. Operating & storage temperature ranges: -40°C ~ +85°C
6. Agency recognition: UL / cUL / TUV

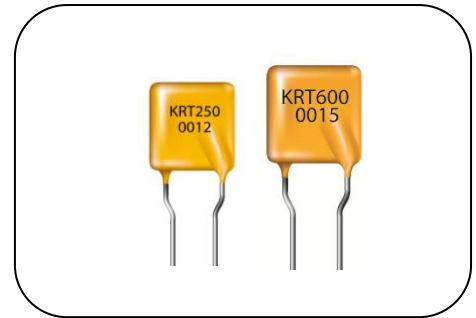

■ Recommended Applications

1. Telecommunication
2. Network equipment
3. Set-top box

■ Part Number Code

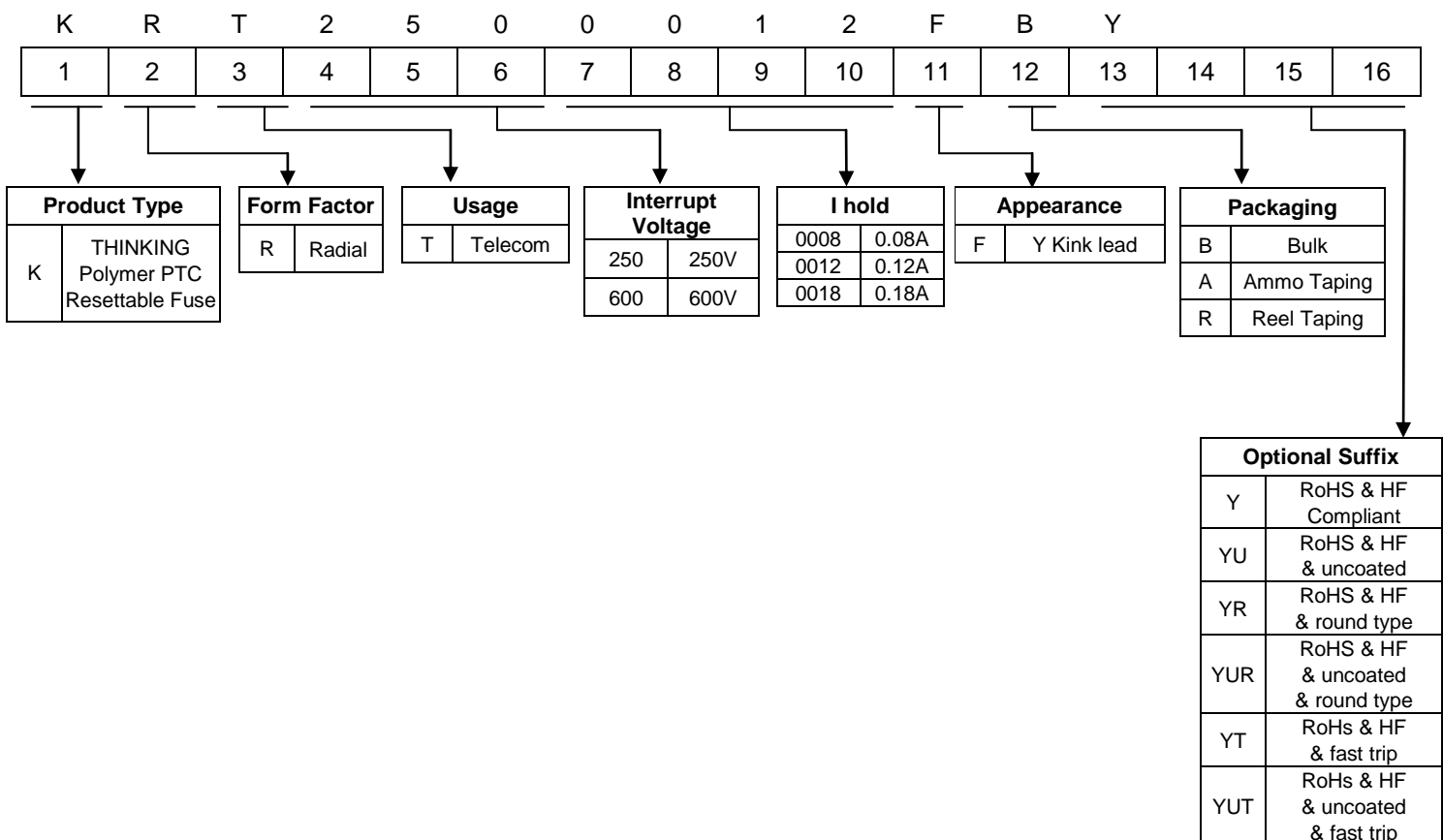

Polymer PTC Resettable Fuse: KRT Series

Radial Lead Type For Telecom Applications



Structure and Dimensions

KRT250 Series

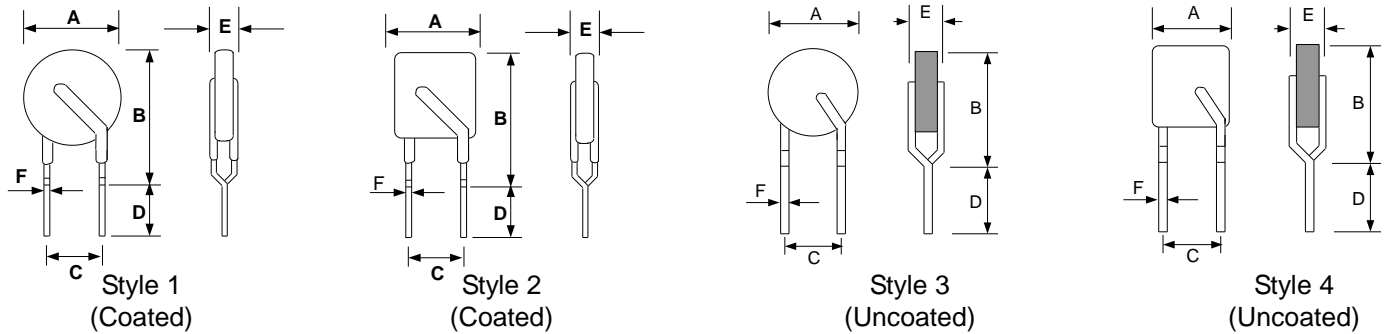

Marking: Coated device is marked with product type, max. interrupt voltage, and I hold.

(Unit: mm)

Part No.	A	B	C	D	E	F	Figure Style
	Max.	Max.	Typ.	Min.	Max.	Typ.	
KRT2500008	5.8	9.6	5.0±0.8	4.7	4.6	0.6±0.02	1
KRT2500008-U	5.1	9.1	5.0±0.8	4.7	3.8	0.6±0.02	3
KRT2500008-T	5.8	9.9	5.0±0.8	4.7	4.6	0.6±0.02	1
KRT2500011	6.8	9.9	5.0±0.8	4.7	4.6	0.6±0.02	1
KRT2500011-U	5.9	9.4	5.0±0.8	4.7	3.8	0.6±0.02	3
KRT2500012	6.5	11.0	5.0±0.8	4.7	4.6	0.6±0.02	2
KRT2500012-U	6.0	10.0	5.0±0.8	4.7	3.8	0.6±0.02	4
KRT2500012-UT	6.0	10.0	5.0±0.8	4.7	3.8	0.6±0.02	4
KRT2500012-T	6.5	11.0	5.0±0.8	4.7	4.6	0.6±0.02	2
KRT2500015	6.5	11.0	5.0±0.8	4.7	4.6	0.6±0.02	2
KRT2500015-U	6.0	10.0	5.0±0.8	4.7	3.8	0.6±0.02	4
KRT2500015-T	6.5	11.0	5.0±0.8	4.7	4.6	0.6±0.02	2
KRT2500018	11.0	12.6	5.0±0.8	4.7	4.6	0.6±0.02	2
KRT2500018-U	10.4	12.6	5.0±0.8	4.7	3.8	0.6±0.02	4
KRT2500018R	11.0	12.0	5.0±0.8	4.7	3.8	0.6±0.02	1
KRT2500018UR	9.8	12.0	5.0±0.8	4.7	3.5	0.6±0.02	3

KRT600 Series

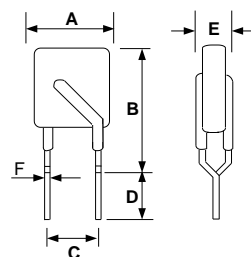

Style 1

(Unit: mm)

Part No.	A	B	C	D	E	F	Figure Style
	Max.	Max.	Typ.	Min.	Max.		
KRT6000015	9.0	12.5	5.0±0.8	4.7	4.6	0.6±0.02	1
KRT6000016	16.0	12.6	5.0±0.8	4.7	6.0	0.6±0.02	1

Polymer PTC Resettable Fuse: KRT Series

Radial Lead Type For Telecom Applications



Electrical Characteristics at 23°C

KRT250 Series

Part No.	V _{max.}	V _{interrupt}	I _{max.}	I _{hold}	I _{trip}	Pd (Typ.)	Maximum Time to Trip		Resistance		Safety Approvals		
	(V _{dc})	(V _{ac})	(A)	(A)	(A)	(W)	Current (A)	Time (Sec.)	Initial Ri Min. (Ω)	Post Trip R1 Max. (Ω)	UL/cUL	TUV	CQC
	KRT2500008	100	250	3.00	0.08	0.16	1.00	0.35	4.00	14.00	33.00	√	√
KRT2500008-U	100	250	3.00	0.08	0.16	1.00	0.35	4.00	14.00	33.00	√	√	√
KRT2500008-T	100	250	3.00	0.08	0.16	1.00	0.35	2.50	15.00	33.00	√	√	√
KRT2500011	100	250	3.00	0.11	0.22	1.00	1.00	2.00	5.00	16.00	√	√	√
KRT2500011-U	100	250	3.00	0.11	0.22	1.00	1.00	2.00	5.00	16.00	√	√	√
KRT2500012	100	250	3.00	0.12	0.24	1.00	1.00	2.00	4.00	16.00	√	√	√
KRT2500012-U	100	250	3.00	0.12	0.24	1.00	1.00	2.00	6.00	16.00	√	√	√
KRT2500012-UT	100	250	3.00	0.12	0.24	1.00	1.00	0.70(typ.) 1.5(max.)	7.00	16.00	√	√	√
KRT2500012-T	100	250	3.00	0.12	0.24	1.00	1.00	0.70(typ.) 1.2(max.)	7.00	16.00	√	√	√
KRT2500015	100	250	3.00	0.145	0.29	1.00	1.00	2.50	3.00	14.00	√	√	√
KRT2500015-U	100	250	3.00	0.145	0.29	1.00	1.00	2.50	3.50	14.00	√	√	√
KRT2500015-T	100	250	3.00	0.145	0.29	1.00	1.00	1.50	5.40	14.00	√	√	√
KRT2500018	100	250	10.00	0.18	0.65	1.50	1.50	11.00	0.80	4.00	√	√	√
KRT2500018-U	100	250	10.00	0.18	0.65	1.50	1.50	10.00	0.80	4.00	√	√	√
KRT2500018R	100	250	10.00	0.18	0.65	1.50	3.00	2.00	0.80	4.00	√	√	√
KRT2500018UR	100	250	10.00	0.18	0.65	1.50	3.00	2.00	0.80	4.00	√	√	√

KRT 600 series

Part No.	V _{max.}	V _{interrupt}	I _{max.}	I _{hold}	I _{trip}	Pd (Typ.)	Maximum Time to Trip		Resistance		Safety Approvals		
	(V _{dc})	(V _{ac})	(A)	(A)	(A)	(W)	Current (A)	Time (Sec.)	Initial Ri Min. (Ω)	Post Trip R1 Max. (Ω)	UL/cUL	TUV	CQC
	KRT6000015	250	600	3.00	0.15	0.30	1.00	1.00	4.00	6.00	17.00	√	√
KRT6000016	250	600	3.00	0.16	0.32	1.70	1.00	7.50	4.00	18.00	√	√	√

Note: UL&cUL File No: E138827

TUV File No: R50161442, J50218395

CQC File No: 13001098048

Polymer PTC Resettable Fuse: KRT Series

Radial Lead Type For Telecom Applications



Typical Time to Trip Curves at 23°C

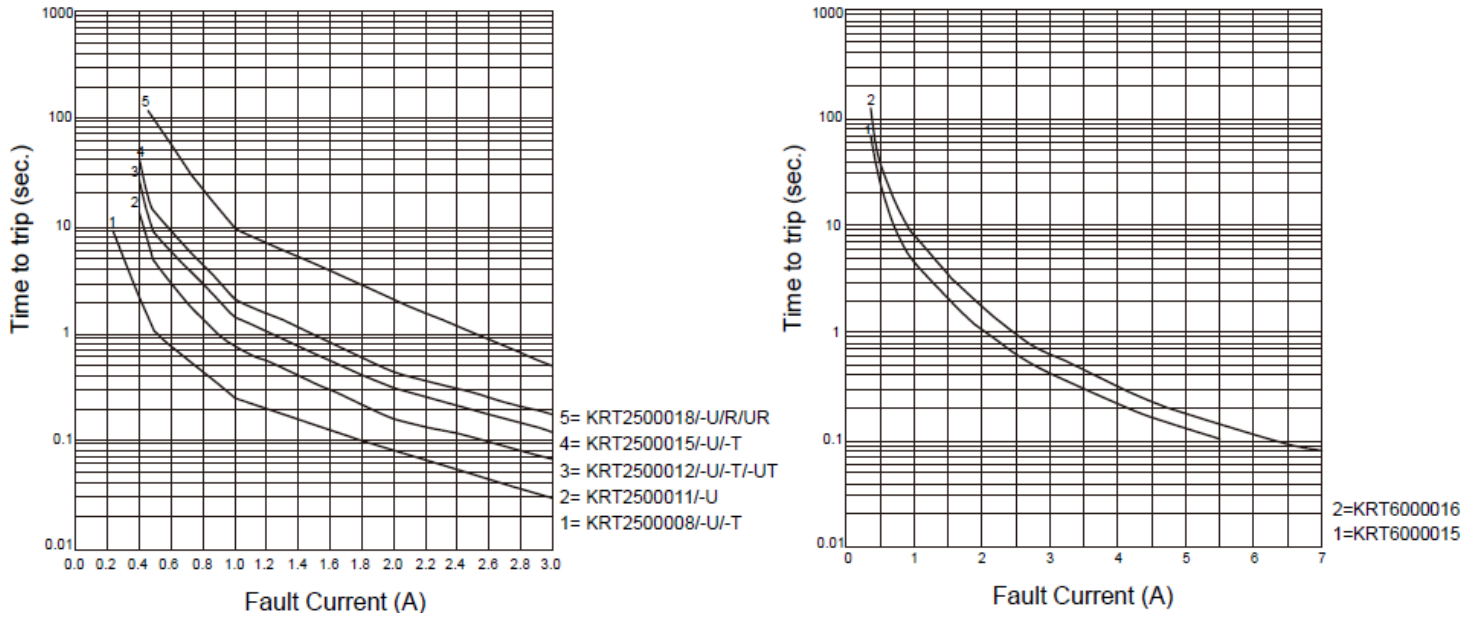

Ihold & Itrip Thermal Derating Curve

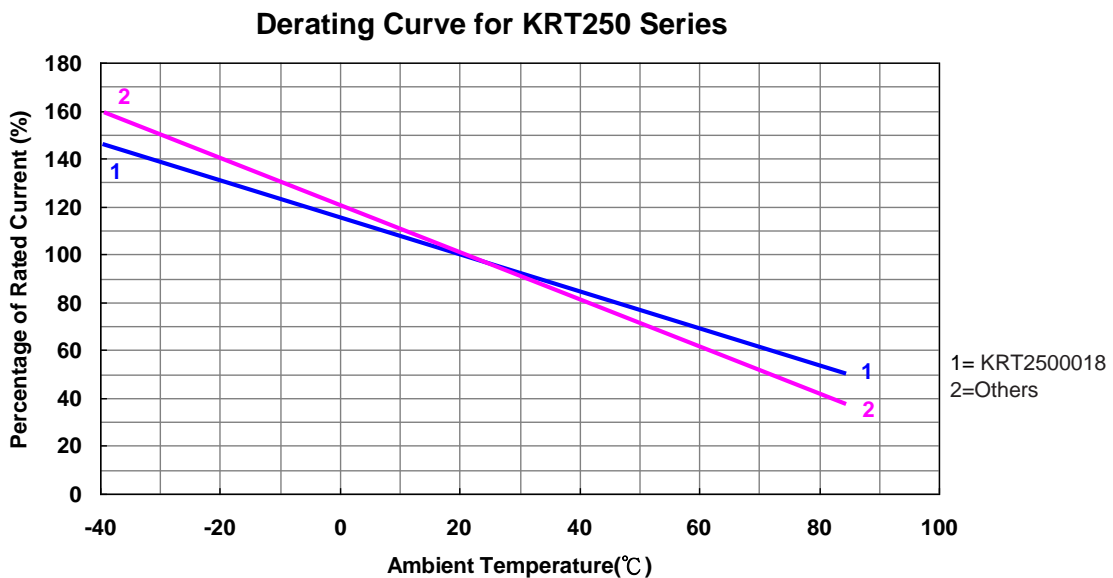

Polymer PTC Resettable Fuse: KRT Series

Radial Lead Type For Telecom Applications

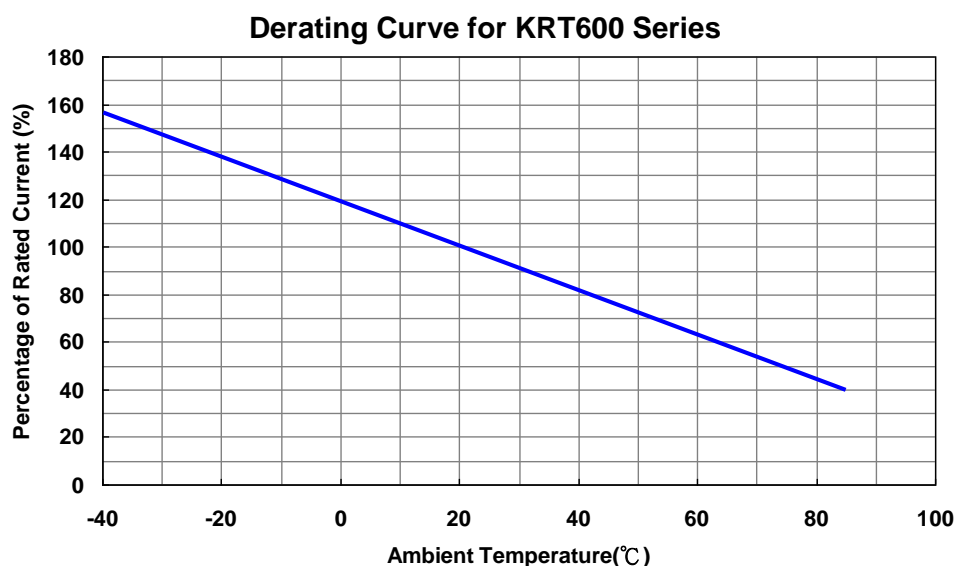

■ Ihold Thermal Derating Chart

(Unit: A)

Part No.	Ambient Temperature								
	-40°C	-20°C	0°C	23°C	40°C	50°C	60°C	70°C	85°C
KRT2500008	0.128	0.112	0.096	0.08	0.064	0.056	0.0488	0.0416	0.032
KRT2500008-U	0.128	0.112	0.096	0.08	0.064	0.056	0.0488	0.0416	0.032
KRT2500008-T	0.128	0.112	0.096	0.08	0.064	0.056	0.0488	0.0416	0.032
KRT2500011	0.176	0.154	0.132	0.11	0.088	0.077	0.0671	0.0572	0.044
KRT2500011-U	0.176	0.154	0.132	0.11	0.088	0.077	0.0671	0.0572	0.044
KRT2500012	0.192	0.168	0.144	0.12	0.096	0.084	0.0732	0.0624	0.048
KRT2500012-U	0.192	0.168	0.144	0.12	0.096	0.084	0.0732	0.0624	0.048
KRT2500012-UT	0.192	0.168	0.144	0.12	0.096	0.084	0.0732	0.0624	0.048
KRT2500012-T	0.192	0.168	0.144	0.12	0.096	0.084	0.0732	0.0624	0.048
KRT2500015	0.240	0.210	0.180	0.15	0.120	0.105	0.0915	0.0780	0.060
KRT250015-U	0.240	0.210	0.180	0.15	0.120	0.105	0.0915	0.0780	0.060
KRT250015-T	0.240	0.210	0.180	0.15	0.120	0.105	0.0915	0.0780	0.060
KRT2500018	0.288	0.252	0.216	0.18	0.144	0.126	0.1098	0.0936	0.072
KRT2500018-U	0.288	0.252	0.216	0.18	0.144	0.126	0.1098	0.0936	0.072
KRT2500018R	0.261	0.234	0.212	0.18	0.158	0.144	0.1260	0.1170	0.094
KRT2500018UR	0.261	0.234	0.212	0.18	0.158	0.144	0.1260	0.1170	0.094
KRT6000015	0.240	0.210	0.180	0.15	0.120	0.105	0.0915	0.0780	0.060
KRT6000016	0.256	0.224	0.192	0.16	0.128	0.112	0.0976	0.0832	0.064

Polymer PTC Resettable Fuse: KRT Series

Radial Lead Type For Telecom Applications



■ Reliability

Item	Standard	Test Conditions / Methods	Criteria
Resistance to Soldering Heat	IEC 60068-2-58	260 ± 5 °C , 10 ± 1 sec	Rf<R1max No visible damage
Passive Aging	IEC 60738-1	85±5°C , 1000±24hrs	±5% typical resistance change
Humidity Aging	IEC60068-2-78	85±5°C , 80~85%RH,1000±5hrs	±5% typical resistance change
Rapid Change of Temperature	IEC 60738-1	85±5/-40±5°C , 10 cycles, Duration: 30min	±5% typical resistance change
Overload and Endurance Test	UL 1434	Vmax, 120% Imax, 50 cycles Vmax, 300% Itrip, 6000 cycles	No visible damage
Aging Test	UL 1434	Vmax, Itrip ≤ I ≤ Imax, 1000±24hrs	No visible damage

■ Packaging

Devices are taped according to IEC 60286-2 standard. See table below and Figure1 to Figure 3 for details.

Dimension description	IEC Mark	Dimension (mm)	Tolerance (mm)
Sprocket hole pitch	P ₀	12.70	±0.3
Ordinate to adjacent component lead	P ₁	3.85	±0.7
Device pitch KRT2500008-KRT2500018 , KRT6000015	P	12.70	±1.0
Device pitch KRT6000016		25.40	
Lead spacing	F	5.00	±0.8
Lead diameter	d	0.60	±0.02
Carrier tape width	W	18.00	+1/-0.5
Top distance between tape edges	W ₂	3.00	Max
Hold-down tape width	W ₀	12.00	±1.0
Sprocket hole position	W ₁	9.00	+0.75/-0.5
Abscissa to top	H ₁	32.20	Max.
Abscissa to plane (kinked lead)	H ₀	16.00	±0.5
Sprocket hole diameter	D ₀	4.00	±0.2
Lead protrusion	L ₁	0.50	Max
Tape thickness	T	0.60	±0.2
Body lateral deviation	Δh	2.00	Max.
Body tape plane deviation	Δp	1.00	Max.
Reel width	W ₃	46.00	±1
Reel diameter		340.00	±10
Arbor hole diameter	n ₀	31.00	±1
Core diameter	n	80.00	Min.

Polymer PTC Resettable Fuse: KRT Series

Radial Lead Type For Telecom Applications



● Taping Specification

Fig. 1 For KRT2500008, KRT2500011, KRT2500018R, KRT2500018UR

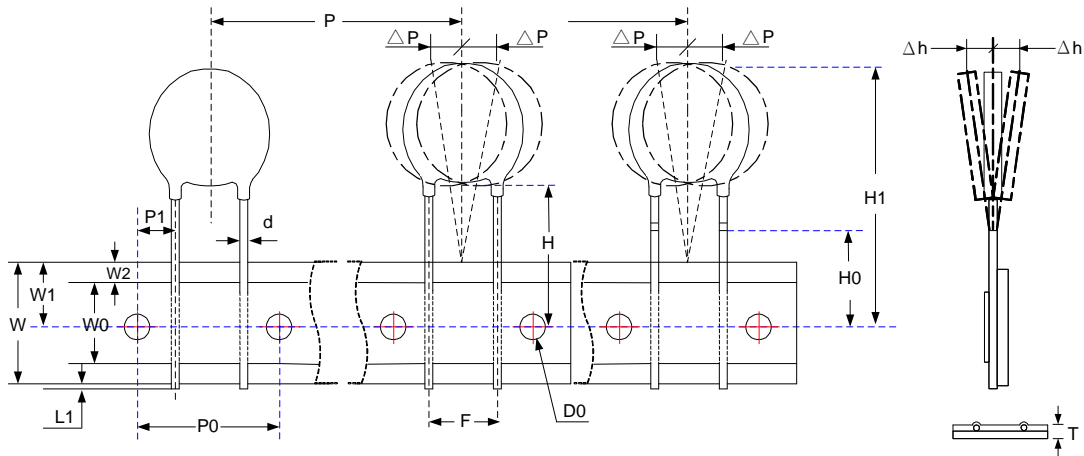
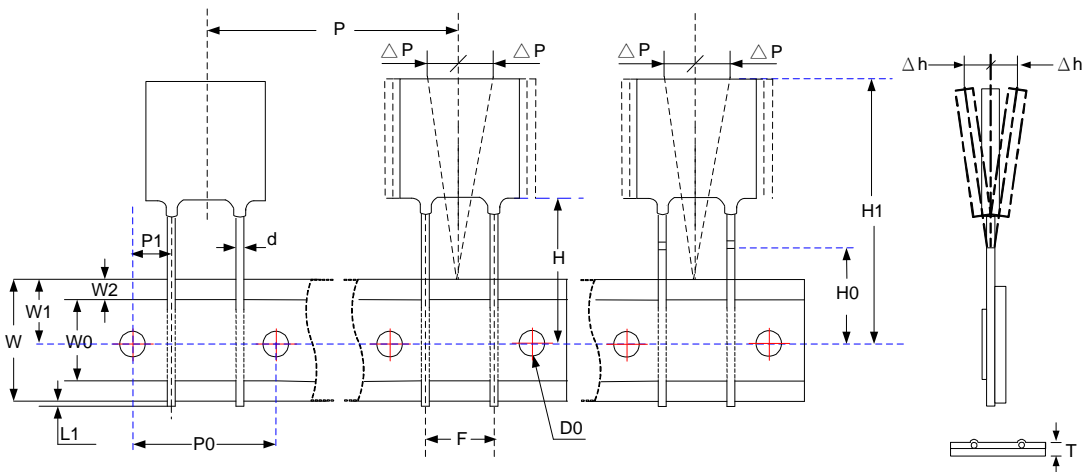
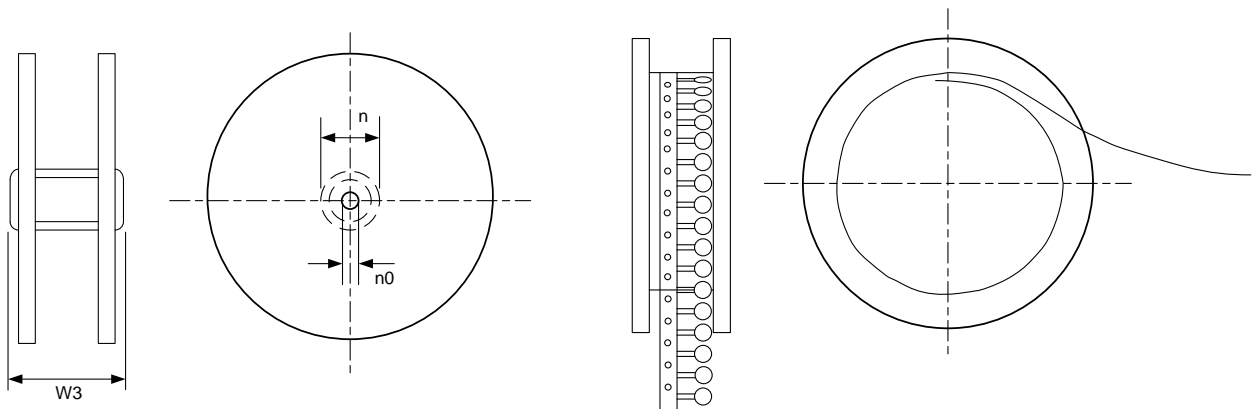

Fig. 2 For KRT2500012 ~ KRT2500018, KRT6000015, KRT6000016



● Reel Specification

Fig. 3



Polymer PTC Resettable Fuse: KRT Series

Radial Lead Type For Telecom Applications



■ Quantity

● Bulk Packing

Series	Quantity (pcs/bag)
KRT250 (0008 ~ 0015)	300
KRT2500018	200
KRT600 series	100

● Reel Packing

Series	Quantity (pcs/reel)
KRT250 (0008 ~ 0015)	1,500
KRT2500018, KRT6000015	1,200
KRT6000016	600

● Ammo Packing

Series	Quantity (pcs/box)
KRT250 series	500
KRT600 series	500

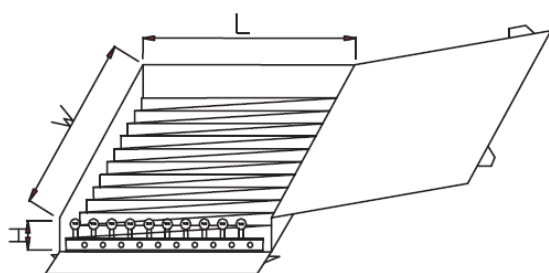

(Unit: mm)

Series	W	L	H
KRT250/KRT600	348	185	50

■ Warehouse Storage Conditions of Products

● Storage Conditions:

1. Storage Temperature: $-10^{\circ}\text{C} \sim +40^{\circ}\text{C}$
2. Relative Humidity: $\leq 75\%RH$
3. Keep away from corrosive atmosphere and sunlight.

● Period of Storage : 1 year