



SDC4D28 SERIES~ SMD Shielded Power Inductors



PART NUMBERING SYSTEM

SDC	4D28	—	6R8N	—	LF
TYPE	DIMENSIONS		INDUCTANCE		LEAD FREE

SHAPES AND DIMENSIONS

UNIT : mm

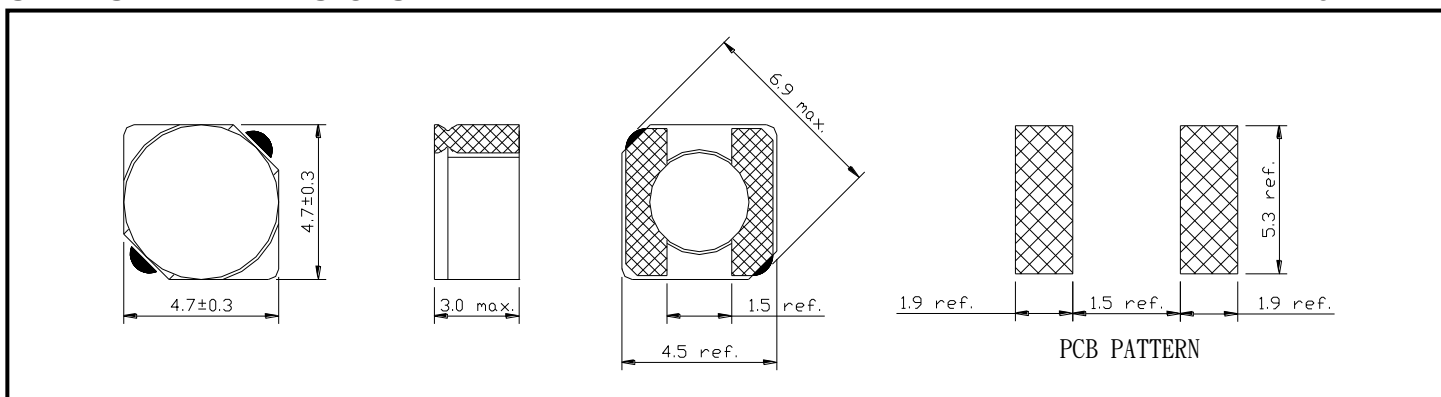

PACKAGING SPECIFICATION

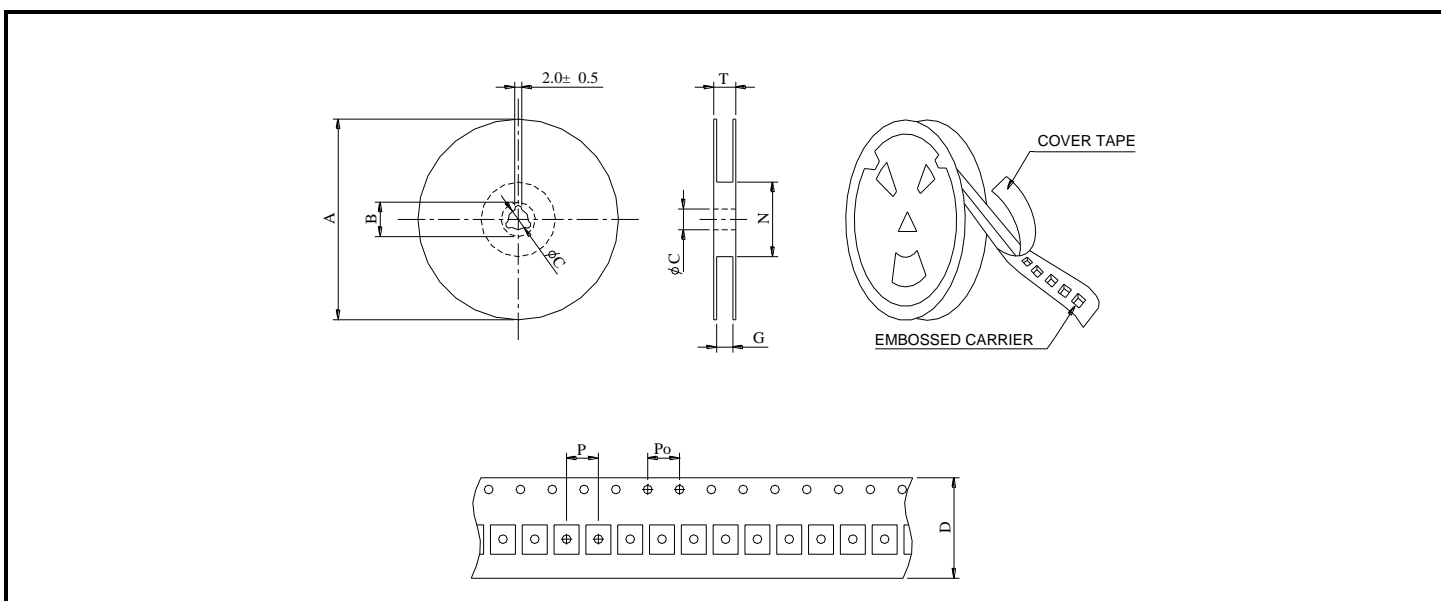

SERIES	STAYLE	Q' TY (PCS)	DIMENSIONS (m/m)								
			A	B±0.8	C±0.5	D	G ⁺	N ⁰	P	Po	T
SDC4D28	13-16	2000	330	21	13	16	18	50	8	4	22.4

SDC4D28 SERIES~ SMD Shielded Power Inductors



SPECIFICATION TABLE

PART NUMBER	INDUCTANCE (μ H)	DCR (m Ω) (Max.)	IDC (A)	TEST FREQ. (f)
SDC4D28-1R2N-LF	1.2 \pm 30%	23.6	2.56	100KHz
SDC4D28-1R8N-LF	1.8 \pm 30%	27.5	2.20	100KHz
SDC4D28-2R2N-LF	2.2 \pm 30%	31.3	2.04	100KHz
SDC4D28-2R7N-LF	2.7 \pm 30%	43.3	1.60	100KHz
SDC4D28-3R3N-LF	3.3 \pm 30%	49.2	1.57	100KHz
SDC4D28-3R9N-LF	3.9 \pm 30%	64.8	1.44	100KHz
SDC4D28-4R7N-LF	4.7 \pm 30%	72.0	1.32	100KHz
SDC4D28-5R6N-LF	5.6 \pm 30%	100.9	1.17	100KHz
SDC4D28-6R8N-LF	6.8 \pm 30%	108.9	1.12	100KHz
SDC4D28-8R2N-LF	8.2 \pm 30%	117.5	1.04	100KHz
SDC4D28-100N-LF	10 \pm 30%	128.3	1.00	100KHz
SDC4D28-120N-LF	12 \pm 30%	131.6	0.84	100KHz
SDC4D28-150N-LF	15 \pm 30%	149.0	0.76	100KHz
SDC4D28-180N-LF	18 \pm 30%	166.0	0.72	100KHz
SDC4D28-220M-LF	22 \pm 20%	235.0	0.70	100KHz
SDC4D28-270M-LF	27 \pm 20%	261.0	0.58	100KHz
SDC4D28-330M-LF	33 \pm 20%	331.3	0.56	100KHz
SDC4D28-390M-LF	39 \pm 20%	383.7	0.50	100KHz
SDC4D28-470M-LF	47 \pm 20%	587.0	0.48	100KHz
SDC4D28-560M-LF	56 \pm 20%	624.5	0.41	100KHz
SDC4D28-680M-LF	68 \pm 20%	699.0	0.35	100KHz
SDC4D28-820M-LF	82 \pm 20%	914.8	0.32	100KHz
SDC4D28-101M-LF	100 \pm 20%	1020.0	0.29	100KHz
SDC4D28-121M-LF	120 \pm 20%	1270.0	0.27	100KHz
SDC4D28-151M-LF	150 \pm 20%	1350.0	0.24	100KHz
SDC4D28-181M-LF	180 \pm 20%	1540.0	0.22	100KHz

- Isat : DC current at which the inductance drops 35% (typ) from its value without current.
- Irms: The actual current when temperature of coil becomes $\Delta 40^{\circ}\text{C}$. ($T_a=+25^{\circ}\text{C}$)
- Operating temperature range -40°C to $+125^{\circ}\text{C}$, Electrical specifications at 25°C .