



SEP1205E SERIES~ High Current SMD Power Inductors



PART NUMBERING SYSTEM

SEP	1205E	—	1R0M	—	LF
TYPE	DIMENSIONS		INDUCTANCE		LEAD FREE

SHAPES AND DIMENSIONS :

UNIT : mm



FEATURES :

- * DC current up to 118Amp.
- * Magnetically shielded low DC resistance .
- * Suitable for large current application.
- * Laptop & Notebook computers.
- * Battery powered equipment.
- * DC/DC converters.
- * Digital 、 Cameras 、 Scanners, CD-ROM & DVD.

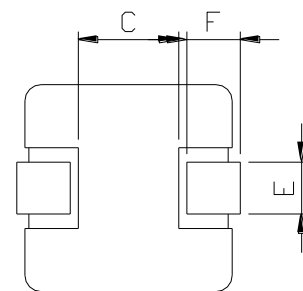
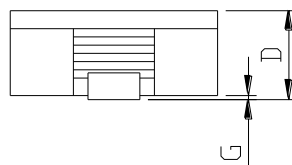
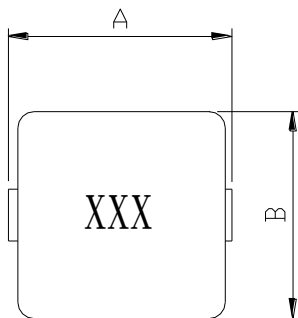

A=13.5±1.0 B=12.8±0.5 C=6.0 Ref. D=5.0 Max. E=3.8 Ref. F=2.5 Ref. G=0.2 Max.

RECOMMENDED PATTERNS

UNIT : mm

H=10.25

I= 5.00

J= 4.25

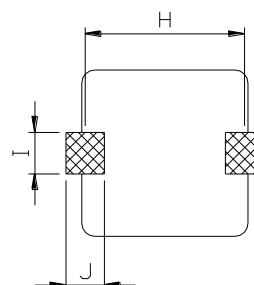



SEP1205E SERIES~ High Current SMD Power Inductors



SPECIFICATION TABLE

PART NUMBER	INDUCTANCE (μ H)	I _{sat} (A) (Max.)	I _{rms} (A) (Δ t) 40°C (Max.)	DCR (m Ω) (Max.)	Test Freq. (KHz)
SEP1205E-R10M-LF	0.10 \pm 20%	118	55	0.60	100KHz/1V
SEP1205E-R22M-LF	0.22 \pm 20%	110	51	0.80	100KHz/1V
SEP1205E-R33M-LF	0.33 \pm 20%	80	42	1.10	100KHz/1V
SEP1205E-R47M-LF	0.47 \pm 20%	65	38	1.30	100KHz/1V
SEP1205E-R56M-LF	0.56 \pm 20%	55	36	1.50	100KHz/1V
SEP1205E-R68M-LF	0.68 \pm 20%	54	34	1.70	100KHz/1V
SEP1205E-R82M-LF	0.82 \pm 20%	53	31	2.30	100KHz/1V
SEP1205E-1R0M-LF	1.00 \pm 20%	50	29	2.50	100KHz/1V
SEP1205E-1R2M-LF	1.20 \pm 20%	49	25	3.50	100KHz/1V
SEP1205E-1R5M-LF	1.50 \pm 20%	48	23	4.10	100KHz/1V
SEP1205E-1R8M-LF	1.80 \pm 20%	40	19	4.90	100KHz/1V
SEP1205E-2R2M-LF	2.20 \pm 20%	32	20	5.50	100KHz/1V
SEP1205E-3R3M-LF	3.30 \pm 20%	32	15	9.20	100KHz/1V
SEP1205E-4R7M-LF	4.70 \pm 20%	27	12	15.0	100KHz/1V
SEP1205E-5R6M-LF	5.60 \pm 20%	22	11.5	16.5	100KHz/1V
SEP1205E-6R8M-LF	6.80 \pm 20%	21	11	18.5	100KHz/1V
SEP1205E-7R8M-LF	7.80 \pm 20%	18	10	20.5	100KHz/1V
SEP1205E-8R2M-LF	8.20 \pm 20%	18	9.5	22.5	100KHz/1V
SEP1205E-100M-LF	10.0 \pm 20%	16	9.0	25.5	100KHz/1V

- Inductance measured at 100 kHz, 0.1 V_{rms} .
- I_{sat} : DC current at which the inductance drops 20% (typ) from its value without current.
- I_{rms} : Average current for a 40°C temperature rise above 25°C ambient.
- Operating temperature range -55°C to +125°C , Electrical specifications at 25°C.



SEP1205E SERIES~ High Current SMD Power Inductors



PACKAGING SPECIFICATION

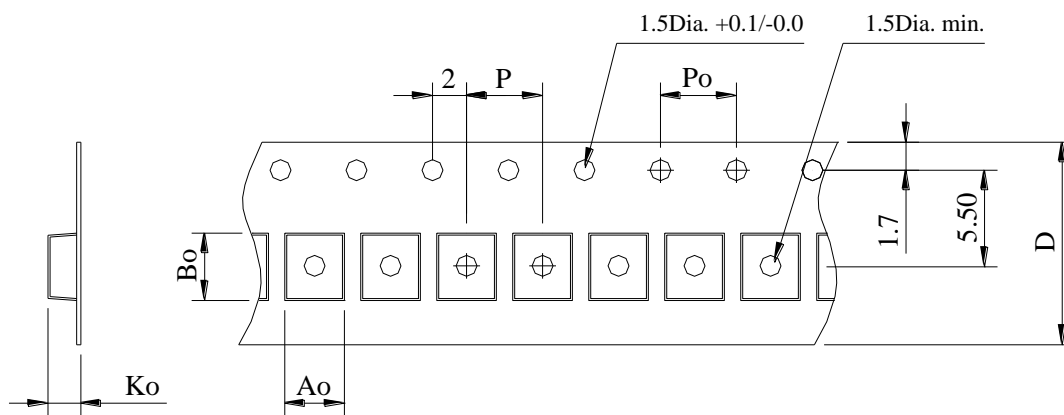

STAYLE	Q'TY (PCS)	DIMENSIONS (m/m)					
		A_o	B_o	K_o	P	P_o	$D \pm 0.3$
13"	500	14.2	13.5	4.1	20	4.0	24