

Ceramic PTC Thermistor: PPL Series

Dip Type for Inrush Current Limiter



■ Features

1. RoHS compliant
2. Leaded type
3. Voltage rating: $270V_{ac} \sim 500V_{ac}$
4. Resistance range: $10 \sim 1000\Omega$
5. Stable over a long time
6. Operating temperature range:
 - 20 ~ +85°C ($V=V_{max}$)
 - 40 ~ +125°C ($V=0$)
7. Agency recognition:
 - UL/cUL File No. E138827

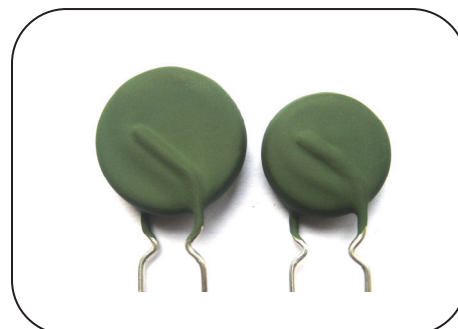

■ Recommended Applications

1. Air conditioner
2. Server
3. LED lamp
4. Switch power supply

■ Part Number Code

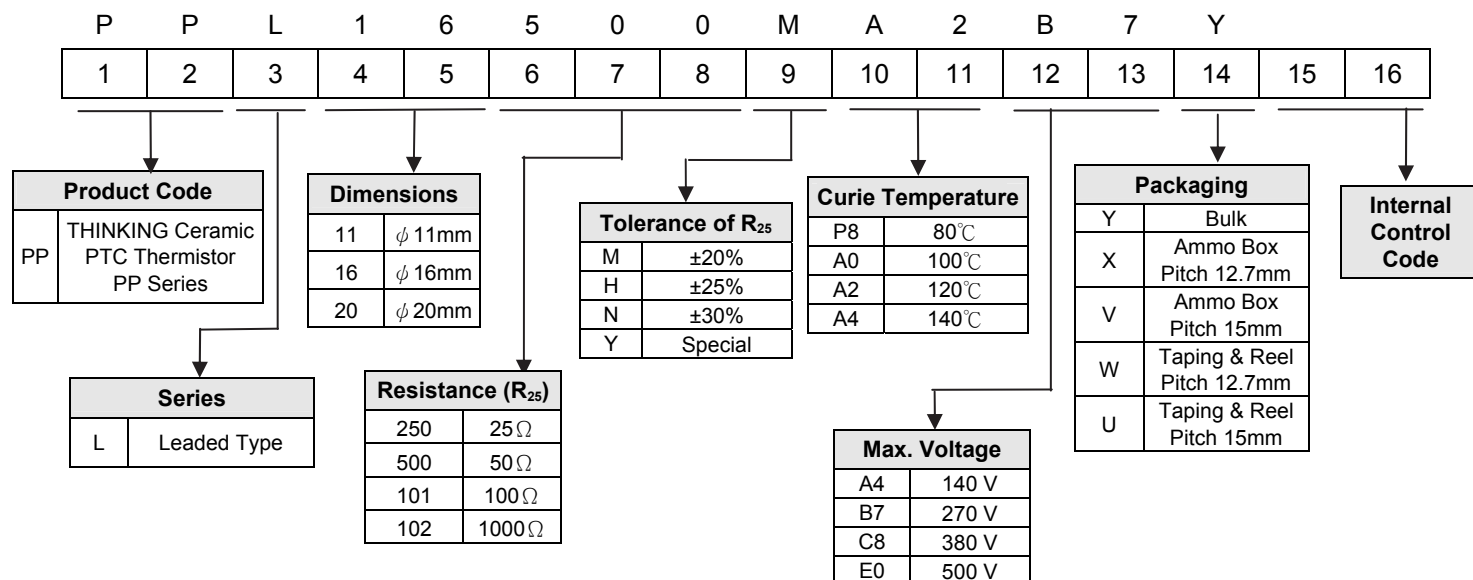

Ceramic PTC Thermistor: PPL Series

Dip Type for Inrush Current Limiter



■ Structure and Dimensions

● Structure

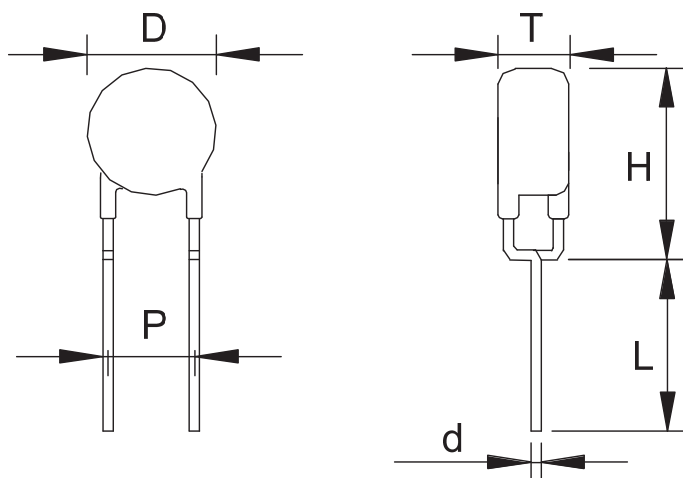

● Dimensions

(Unit: mm)

Part No.	D	T	H	d	P	L
	max	max	max	± 0.02	± 1.0	Min.
PPL19100□A1B7	21.5	10.7	25.5	1.0	10	25
PPL16270□A2B7	18	7	21.5	1.0	10	25
PPL20330□A3B7	22	10.7	25.5	1.0	10	25
PPL16350□A2B7	18	7	21.5	1.0	10	25
PPL16500□A2B7	18	7	21.5	1.0	10	25
PPL11250□A2C8	13	6	17	0.6	5	25
PPL11500□A2C8	13	7	17	0.6	5	25
PPL11800□A2C8	13	7	17	0.6	5	25
PPL19500□A0C8	21.5	10.7	25.5	1.0	10	25
PPL11121□A2C8	13	7	17	0.6	5	25
PPL11151□A2C8	13	7	17	0.6	5	25
PPL14121□A3D4	15	7.5	19.5	0.8	5	25
PPL19102□A0D8	21.5	10.7	25.5	1.0	10	25
PPL16251□A2E0	18	7	21.5	1.0	10	25
PPL11501□A2E0	13	7	17	0.6	5	25

Ceramic PTC Thermistor: PPL Series

Dip Type for Inrush Current Limiter



■ Characteristics

Part No.	Max. Voltage	Zero-power Resistance at 25°C	Curie Temperature	Thermal Capacity	Max. Non-operating Energy at 60°C	Safety Approvals
	Vmax (Vac)	R ₂₅ (Ω)	T _c (°C)	C _{th} (J/K)	E _{Non60} (J)	UL/cUL
PPL19100□A1B7	270	10	110	3.5	123	
PPL16270□A2B7	270	27	120	2.3	97	
PPL20330□A3B7	270	33	130	3.8	186	
PPL16350□A2B7	270	35	120	2.3	97	
PPL16500□A2B7	270	50	120	2.3	97	√
PPL11250□A2C8	380	25	115	1.0	39	√
PPL11500□A2C8	380	50	115	1.4	54	√
PPL11800□A2C8	380	80	115	1.4	54	√
PPL19500□A0C8	380	50	100	3.5	98	
PPL11121□A2C8	380	120	115	1.4	54	√
PPL11151□A2C8	380	150	115	1.4	54	√
PPL14121□A3D4	440	120	130	2.1	103	
PPL19102□A0D8	480	1000	100	3.8	106	
PPL16251□A2E0	500	250	120	2.3	97	
PPL11501□A2E0	500	500	115	1.4	54	√

Note: □ is the tolerance of R₂₅

■ Application and Selection

● Typical application circuit:

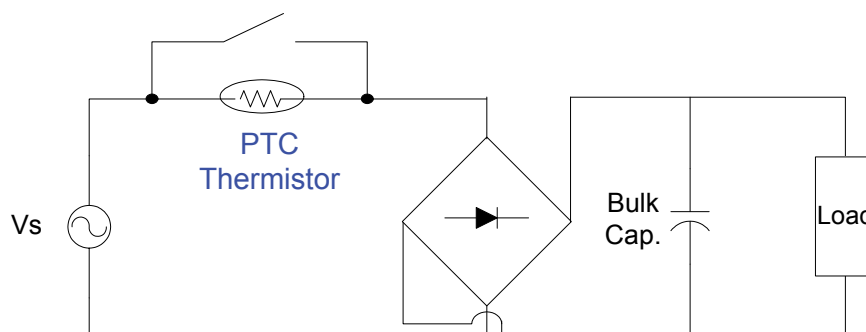

● Selection

Select charging capacitor according to the following formula.

$$C < \frac{0.7 \times (T_c - T_a) \times C_{th} \times 10^6}{0.5 \times V^2} \quad (\text{Unit: } \mu\text{F})$$

C: Bulk Cap.

T_c: Curie temperature of PTC

V: Voltage of capacitor charging ($V=1.414 \times V_s$)

0.7: Safety factor

T_a: Ambient temperature

$$E_{\text{Non60}} = 0.7 \times (T_c - T_a) \times C_{th}$$

E_{Non60}: Max Non-operating Energy at 60°C (T_a= 60)

Ceramic PTC Thermistor: PPL Series

Dip Type for Inrush Current Limiter



■ R-T Characteristic Curve (Typical)

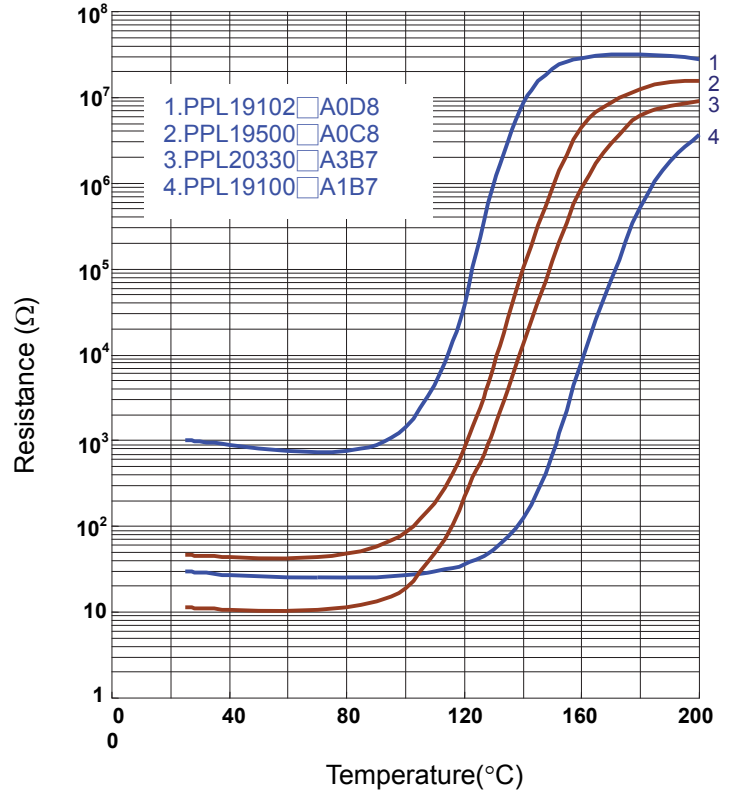
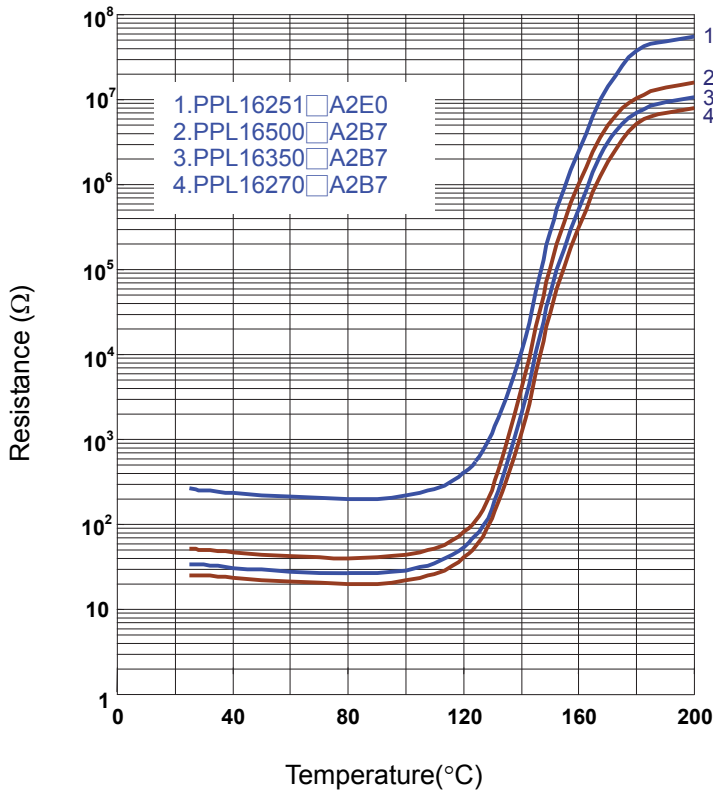
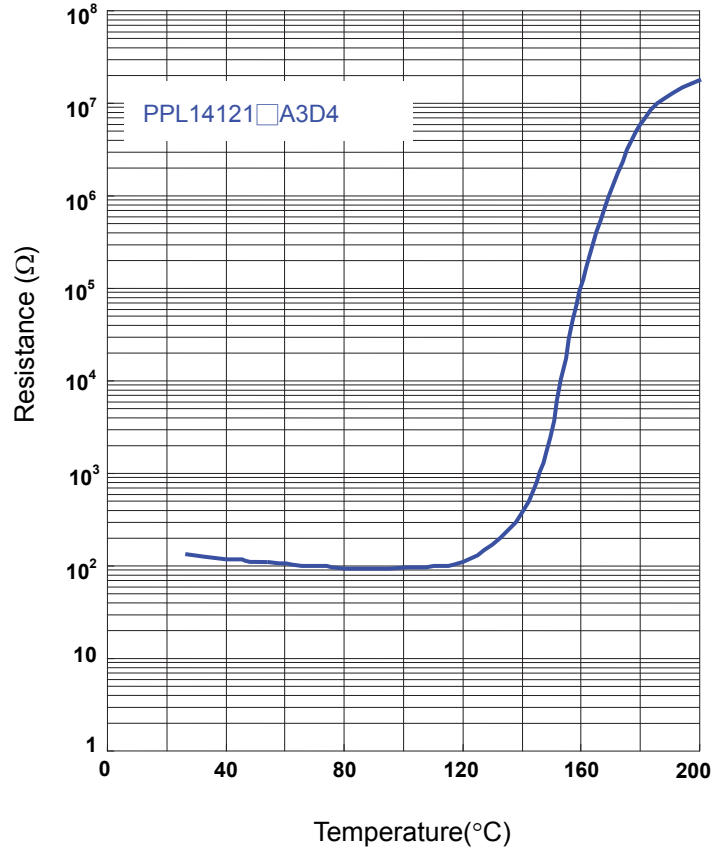
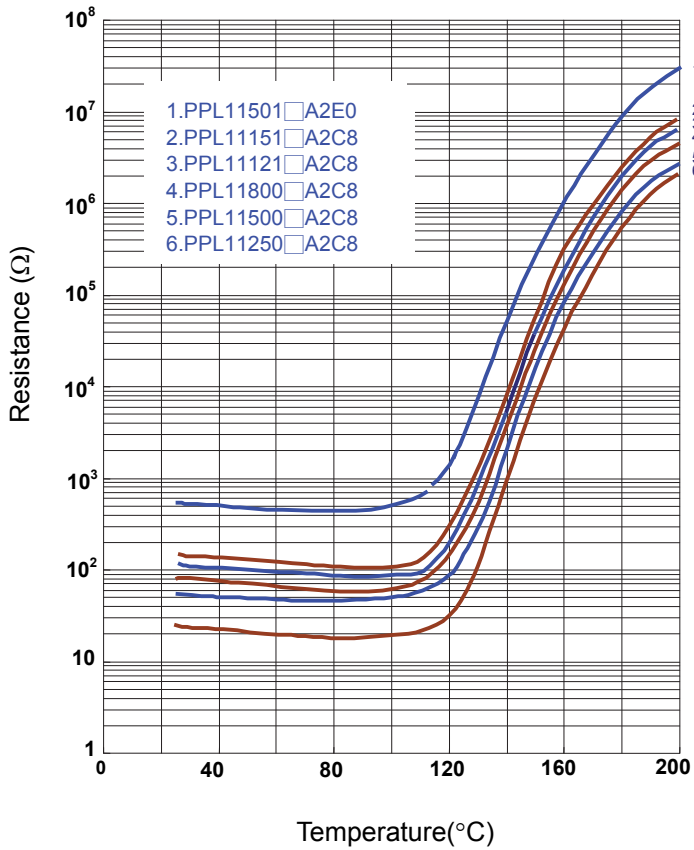

Ceramic PTC Thermistor: PPL Series

Dip Type for Inrush Current Limiter



■ Soldering Recommendation

● Wave Flow Soldering Profile

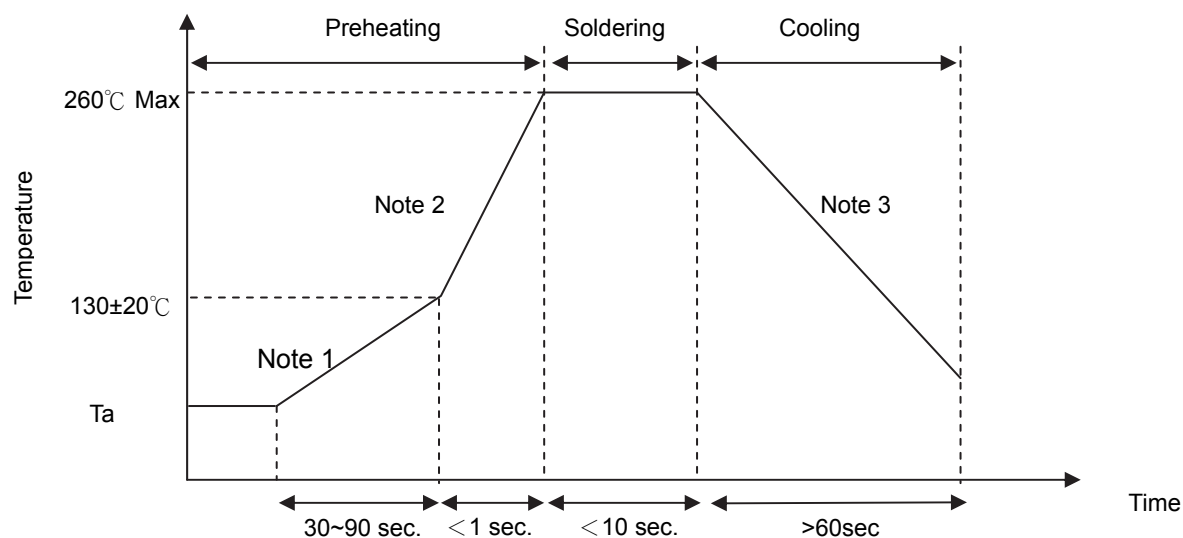

Note

- 1: (1~3°C)/sec
- 2: Approx. 200°C/sec
- 3: 5°C/sec. (Max)

■ Recommended Reworking Conditions With Soldering Iron

Item	Conditions
Temperature of Soldering Iron-tip	360°C (max.)
Soldering Time	3 sec (max.)
Distance from Thermistor	2 mm (min.)

Ceramic PTC Thermistor: PPL Series

Dip Type for Inrush Current Limiter



■ Reliability Test

Item	Standard	Test Conditions and Methods	Specifications															
Robustness of Terminations	IEC 60738-1	Gradually apply the specified force and keep the unit fixed for 10±1 sec. <table style="width: 100%; border-collapse: collapse;"> <tr> <td style="text-align: center; border-bottom: 1px solid black;">Terminal diameter (mm)</td> <td style="text-align: center; border-bottom: 1px solid black;">Force T(N)</td> </tr> <tr> <td style="text-align: center;">0.35<d≤0.5</td> <td style="text-align: center;">5.0</td> </tr> <tr> <td style="text-align: center;">0.5<d≤0.8</td> <td style="text-align: center;">10.0</td> </tr> <tr> <td style="text-align: center;">0.8<d≤1.25</td> <td style="text-align: center;">20.0</td> </tr> </table>	Terminal diameter (mm)	Force T(N)	0.35<d≤0.5	5.0	0.5<d≤0.8	10.0	0.8<d≤1.25	20.0	$ \Delta R_{25}/R_{25} \leq 20\%$ No visible damage							
Terminal diameter (mm)	Force T(N)																	
0.35<d≤0.5	5.0																	
0.5<d≤0.8	10.0																	
0.8<d≤1.25	20.0																	
Solderability	IEC 60738-1	245±3 °C , 2±0.5 sec	At least 95% of terminal electrode is covered by new solder															
Resistance to Soldering Heat	IEC 60738-1	260±3 °C , 10±1 sec	$ \Delta R_{25}/R_{25} \leq 20\%$ No visible damage															
Vibration	IEC 60738-1	Frequency range: 10~55Hz Amplitude: 0.75mm or 98m/s ² Direction: 3 mutually perpendicular directions Duration: 6hrs(3x2 hrs)	$ \Delta R_{25}/R_{25} \leq 20\%$ No visible damage															
Shock	IEC 60738-1	Wave: half-sine ΔV: 1.0m/s Acceleration: 50 m/s ² Pulse time: 30ms	$ \Delta R_{25}/R_{25} \leq 20\%$ No visible damage															
Rapid Change of Temperature	IEC 60738-1	The thermal shock conditions shown below shall be repeated 5 cycles. <table border="1" style="width: 100%; border-collapse: collapse; text-align: center;"> <thead> <tr> <th>Step</th> <th>Temperature (°C)</th> <th>Period (minutes)</th> </tr> </thead> <tbody> <tr> <td>1</td> <td>-40 ± 5</td> <td>30 ± 3</td> </tr> <tr> <td>2</td> <td>Room temperature</td> <td>5 ± 3</td> </tr> <tr> <td>3</td> <td>85 ± 5</td> <td>30 ± 3</td> </tr> <tr> <td>4</td> <td>Room temperature</td> <td>5 ± 3</td> </tr> </tbody> </table>	Step	Temperature (°C)	Period (minutes)	1	-40 ± 5	30 ± 3	2	Room temperature	5 ± 3	3	85 ± 5	30 ± 3	4	Room temperature	5 ± 3	$ \Delta R_{25}/R_{25} \leq 20\%$ No visible damage
Step	Temperature (°C)	Period (minutes)																
1	-40 ± 5	30 ± 3																
2	Room temperature	5 ± 3																
3	85 ± 5	30 ± 3																
4	Room temperature	5 ± 3																
Climatic Sequence	IEC 60738-1	Dry heat: 125 °C for 16 hrs Damp heat first cycle: 40°C, 95% R.H ,cycle time: 24 hrs Cold: -40°C for 2 hrs Damp heat (cyclic), remaining cycles: 5 cycles Test according to IEC60068-2-30	$ \Delta R_{25}/R_{25} \leq 20\%$ No visible damage															
Damp Heat, Steady State	IEC 60738-1	40±2°C, 90~95% RH, 1000±2hrs	$ \Delta R_{25}/R_{25} \leq 20\%$ No visible damage															
Endurance at Maximum Operating Temperature and Maximum Voltage	IEC 60738-1	85°C, V _{max} , 1000±2hrs	$ \Delta R_{25}/R_{25} \leq 20\%$ No visible damage															
Endurance Test for Charging of Capacitor	Specification Standard	Operating cycles at V _{max} , 100,000 cycles (charging of capacitor)	$ \Delta R_{25}/R_{25} \leq 20\%$ No visible damage															

Ceramic PTC Thermistor: PPL Series

Dip Type for Inrush Current Limiter



■ Packaging

■ Taping Specification

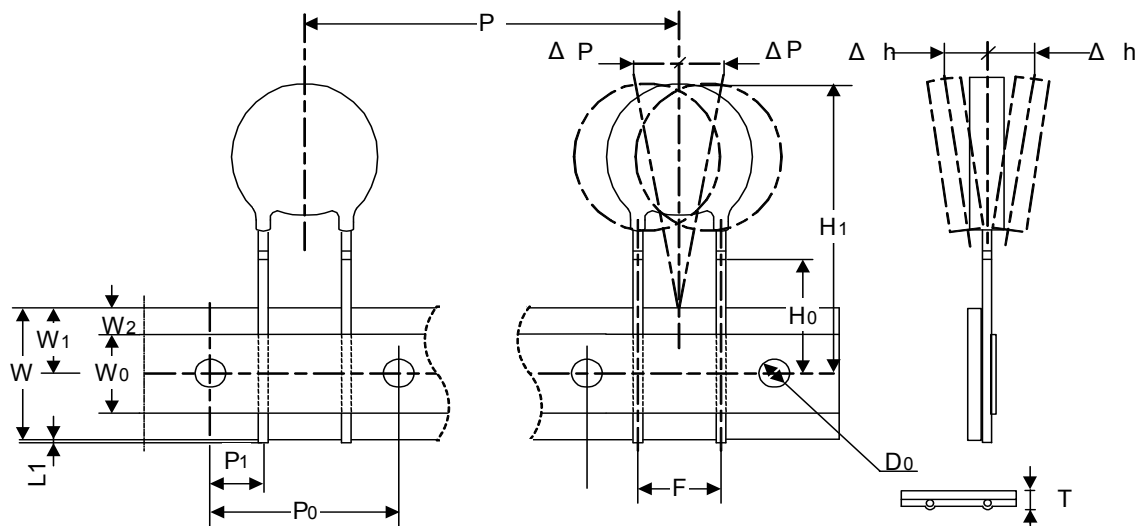

(Unit: mm)

■ Parameter List

Index	Parameter	Nominal dimensions		Tolerance
F	Lead spacing	5		±1
P ₀	Sprocket hole pitch	12.7	15	±0.3
P ₁	Ordinate to adjacent component lead	3.85	5	±1
P	Device pitch	12.7 (D ≤ 10) 25.4 (D > 10)	15.0 (D ≤ 10) 30.0 (D > 10)	±1
H ₀	Abscissa to plane (kinked lead)	16	16	±0.5
H ₁	Abscissa to top	33.5(D=11) 36.0(D=14)		Max.
W	Carrier tape width	18	18	±1
W ₀	Hold-down tape width	12	12	±1
W ₁	Sprocket hole position	9	9	±1
W ₂	Top distance between tape edges	3	3	Max.
ΔP	Body tape plane deviation	1	1	Max.
Δh	Body lateral deviation	2	2	Max.
L ₁	Lead protrusion	0.5	0.5	Max.
D ₀	Sprocket hole diameter	4	4	±0.2
T	Tape thickness	0.6	0.6	±0.2

Note: D is the PTC disc diameter.

Ceramic PTC Thermistor: PPL Series

Dip Type for Inrush Current Limiter



Quantity

Bulk Packing

Disc Size (mm)	Quantity (pcs/bag)
$10 < \Phi < 20$	100
$\Phi \geq 20$	50

Reel Packing

Disc Size (mm)	Quantity (pcs/reel)
$07 < \Phi \leq 12$	750
$12 < \Phi \leq 16$	500
$\Phi > 16$	250

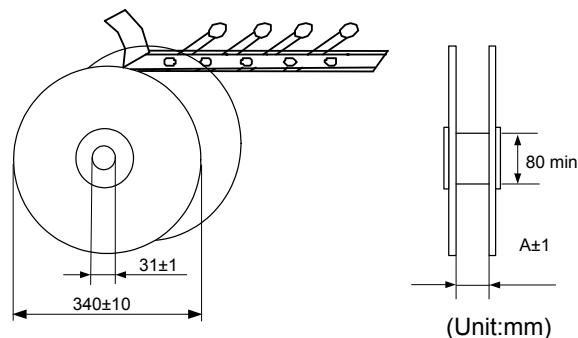

Disc Size	$\Phi < 16$	$\Phi \geq 16$
A	46	55

Ammo Packing

Disc Size (mm)	Quantity (pcs/box)
$07 < \Phi \leq 12$	750
$12 < \Phi \leq 16$	500
$\Phi > 16$	250

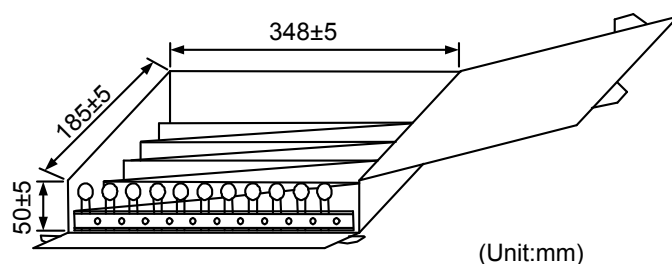

Warehouse Storage Conditions of Products

Storage Conditions :

1. Storage Temperature : $-10^{\circ}\text{C} \sim +40^{\circ}\text{C}$
2. Relative Humidity : $\leq 75\% \text{RH}$
3. Keep away from corrosive atmosphere and sunlight.

Period of Storage : 1 year

Usage

Please keep products away from the conditions mentioned below to avoid their characteristic deterioration and failure.

1. Corrosive gas or deoxidizing gas (Cl_2 , H_2S , NH_3 , SOx , NOx etc.)
2. Place in a vacuum or put pressure
3. Salt water, oil, solvent and chemical liquid
4. Flammable gas
5. Place in splashed water, or high humidity and dewing place
6. Other places similar to any conditions mentioned above