

# Ceramic PTC Thermistor: PT Series

## Temperature Sensor



### ■ Features

1. RoHS compliant
2. Small size
3. Very fast reaction time
4. Wide range of protection temperatures
5. Stable over a long life
6. Operating temperature range:  $0 \sim T_s + 25^\circ\text{C}$  ( $V=V_{\text{max}}$ )
7. Agency Recognition: UL /cUL/CQC

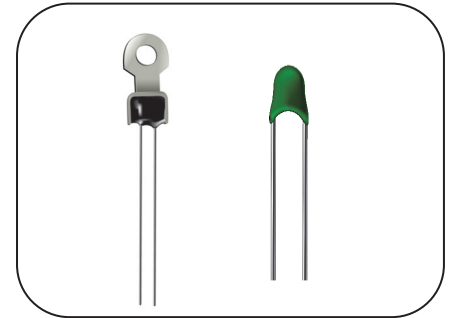

UL&cUL File No. E138827 ; CQC File No. CQC03001008129 / CQC03001008130

### ■ Recommended Applications

1. Lighting applications
2. Home appliances
3. Automotive electronics
4. Motor windings

### ■ Part Number Code

P	T	L	S	2	1	0	1	Y	P	8	1	6	Y		
1	2	3	4	5	6	7	8	9	10	11	12	13	14	15	16

<b>Product Code</b>		<b>Dimension</b>		<b>Tolerance of <math>R_{25}</math></b>		<b>Max. Voltage</b>		<b>Internal Control Code</b>	
PT	THINKING Ceramic PTC Thermistor PT Series	S2	2mm Square	R	$<R_{25}$	16	16V		
				Y	Special	30	30V		

  

<b>Resistance (<math>R_{25}</math>)</b>		<b>Curie Temperature</b>		<b>Packaging</b>	
101	100 $\Omega$	P6	60 $^\circ\text{C}$	Y	Bulk
331	330 $\Omega$	P8	80 $^\circ\text{C}$	X	Ammo Box ,Pitch 12.7mm
		A0	100 $^\circ\text{C}$	W	Taping & Reel, Pitch 12.7mm
		A4	140 $^\circ\text{C}$		

  

<b>Structure</b>	
L	Leaded Type
M	Metal Terminal Type

### ■ Structure and Dimensions

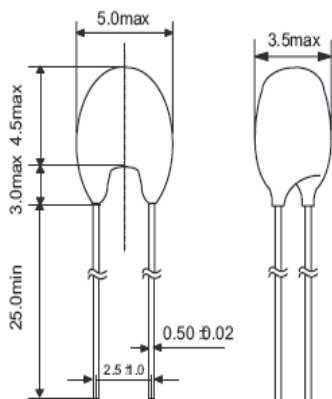

PTL Series

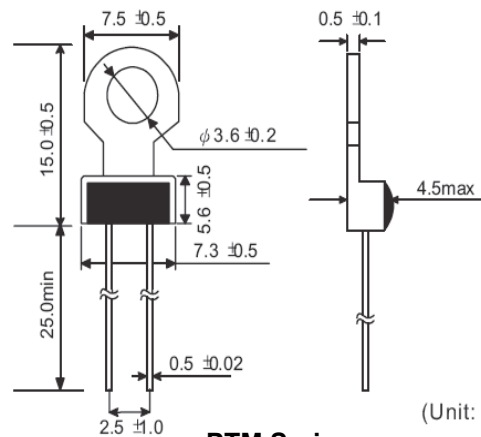

PTM Series

(Unit: mm)

# Ceramic PTC Thermistor: PT Series

## Temperature Sensor



### ■ Characteristics

#### PTL Series

Part No.	Curie Temperature	Sensing Temperature	Resistance Value			Max. Voltage	Max. Current	Safety Approvals	
	T <sub>c</sub> (°C)	T <sub>s</sub> (°C)	25°C (Ω)	T <sub>s</sub> -5°C (Ω)	T <sub>s</sub> +5°C (Ω)	V <sub>max</sub> (V <sub>dc</sub> )	I <sub>max</sub> (mA)	UL/cUL	CQC
PTLS2101□P4**	40±10	55	100 max.	330 max.	470 min.	16/30	100	√	√
PTLS2101□P5**	50±10	65						√	√
PTLS2101□P6**	60±10	75						√	√
PTLS2101□P7**	70±10	85						√	√
PTLS2101□P8**	80±10	95						√	√
PTLS2101□P9**	90±10	105						√	√
PTLS2101□A0**	100±10	115						√	√
PTLS2331□P4**	40±10	55	330 max.	1500 max.	2200 min.			√	√
PTLS2331□P5**	50±10	65						√	√
PTLS2331□P6**	60±10	75						√	√
PTLS2331□P7**	70±10	85						√	√
PTLS2331□P8**	80±10	95						√	√
PTLS2331□P9**	90±10	105						√	√
PTLS2331□A0**	100±10	115						√	√

Note: 1: □ is the tolerance of R<sub>25</sub>

2: \*\* is the maximum voltage (16V<sub>dc</sub> or 30V<sub>dc</sub>)

#### PTL -02/03 Series

Part No.	Curie Temperature	Sensing Temperature	Resistance Value					Max. Voltage	Max. Current	Safety Approvals	
	T <sub>c</sub> (°C)	T <sub>s</sub> (°C)	25°C (Ω)	T <sub>s</sub> -5°C (Ω)	T <sub>s</sub> +5°C (Ω)	T <sub>s</sub> +15°C (Ω)	T <sub>s</sub> +23°C (Ω)	V <sub>max</sub> (V <sub>dc</sub> )	I <sub>max</sub> (mA)	UL/cUL	CQC
PTLS2101□P4**02	40±10	60	100 max.	570 max.	570 min.	—	10K min.	16/30	100	√	√
PTLS2101□P5**02	50±10	70								√	√
PTLS2101□P6**02	60±10	80								√	√
PTLS2101□P7**03	70±10	90								√	√
PTLS2101□P8**03	80±10	100								√	√
PTLS2101□P9**03	90±10	110								√	√
PTLS2101□A0**03	100±10	120		√	√						
PTLS2101□A1**03	110±10	130		550 max.	1330 min.	4000 min.	—				
PTLS2101□A2**03	120±10	140									
PTLS2101□A3**03	130±10	150									
PTLS2101□A4**03	140±10	160									
PTLS2101□A5**03	150±10	170									
PTLS2101□A6**03	160±10	180									

Note: 1: □ is the tolerance of R<sub>25</sub>

2: \*\* is the maximum voltage (16V<sub>dc</sub> or 30V<sub>dc</sub>)

# Ceramic PTC Thermistor: PT Series

## Temperature Sensor



### PTM Series

Part No.	Curie Temperature	Sensing Temperature	Resistance Value			Max. Voltage	Max. Current	Safety Approvals	
	T <sub>c</sub> (°C)	T <sub>s</sub> (°C)	25°C (Ω)	T <sub>s</sub> -5°C (Ω)	T <sub>s</sub> +5°C (Ω)	V <sub>max</sub> (V <sub>dc</sub> )	I <sub>max</sub> (mA)	UL/cUL	CQC
PTMS2101□P4**	40±10	55	100 max.	330 max.	470 min.	16/30	100	√	√
PTMS2101□P5**	50±10	65						√	√
PTMS2101□P6**	60±10	75						√	√
PTMS2101□P7**	70±10	85						√	√
PTMS2101□P8**	80±10	95						√	√
PTMS2101□P9**	90±10	105						√	√
PTMS2101□A0**	100±10	115						√	√
PTMS2331□P4**	40±10	55	330 max.	1500 max.	2200 min.			√	√
PTMS2331□P5**	50±10	65						√	√
PTMS2331□P6**	60±10	75						√	√
PTMS2331□P7**	70±10	85						√	√
PTMS2331□P8**	80±10	95						√	√
PTMS2331□P9**	90±10	105						√	√
PTMS2331□A0**	100±10	115						√	√

Note: 1: □ is the tolerance of R<sub>25</sub>

2: \*\* is the maximum voltage (16V<sub>dc</sub> or 30V<sub>dc</sub>)

### PTM -02/03 Series

Part No.	Curie Temperature	Sensing Temperature	Resistance Value					Max. Voltage	Max. Current	Safety Approvals	
	T <sub>c</sub> (°C)	T <sub>s</sub> (°C)	25°C (Ω)	T <sub>s</sub> -5°C (Ω)	T <sub>s</sub> +5°C (Ω)	T <sub>s</sub> +15°C (Ω)	T <sub>s</sub> +23°C (Ω)	V <sub>max</sub> (V <sub>dc</sub> )	I <sub>max</sub> (mA)	UL/cUL	CQC
PTMS2101□P4**02	40±10	60	100 max.	570 max.	570 min.	—	10K min.	16/30	100	√	√
PTMS2101□P5**02	50±10	70								√	√
PTMS2101□P6**02	60±10	80								√	√
PTMS2101□P7**03	70±10	90		550 max.	1330 min.	4000 min.	—			√	√
PTMS2101□P8**03	80±10	100								√	√
PTMS2101□P9**03	90±10	110								√	√
PTMS2101□A0**03	100±10	120								√	√
PTMS2101□A1**03	110±10	130									
PTMS2101□A2**03	120±10	140									

Note: 1: □ is the tolerance of R<sub>25</sub>

2: \*\* is the maximum voltage (16V<sub>dc</sub> or 30V<sub>dc</sub>)

# Ceramic PTC Thermistor: PT Series

## Temperature Sensor



### ■ R-T Characteristic Curve (Typical)

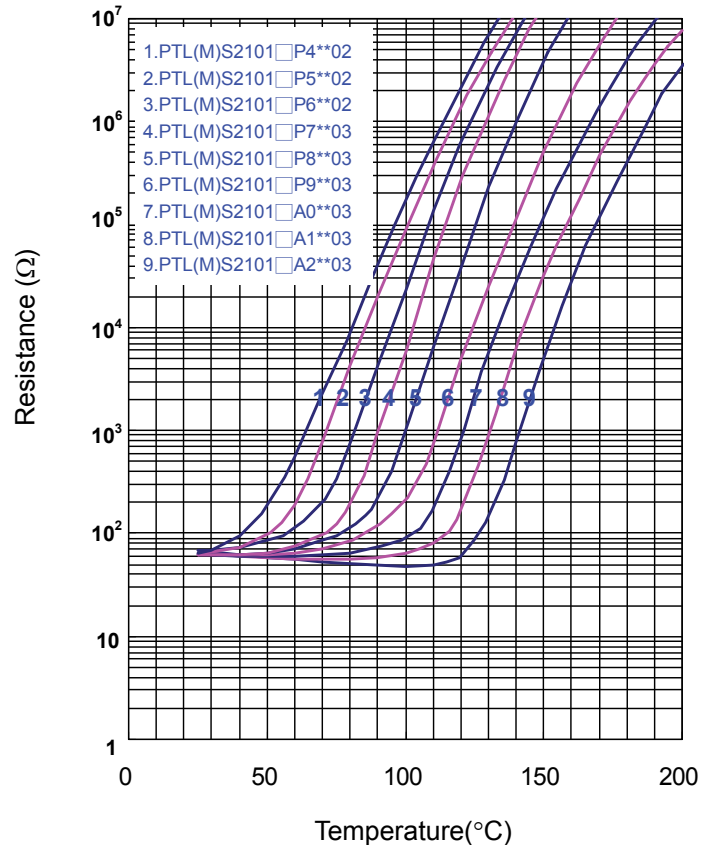
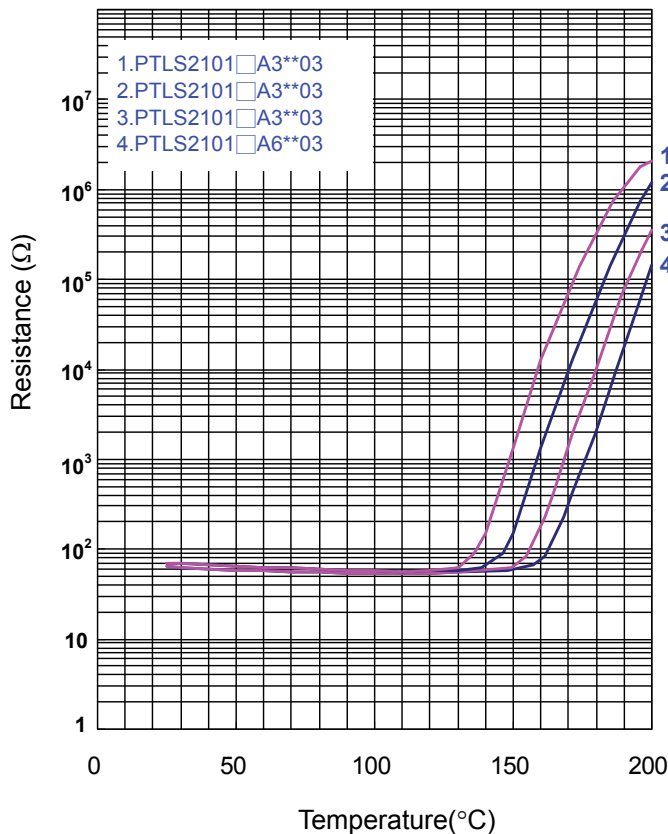
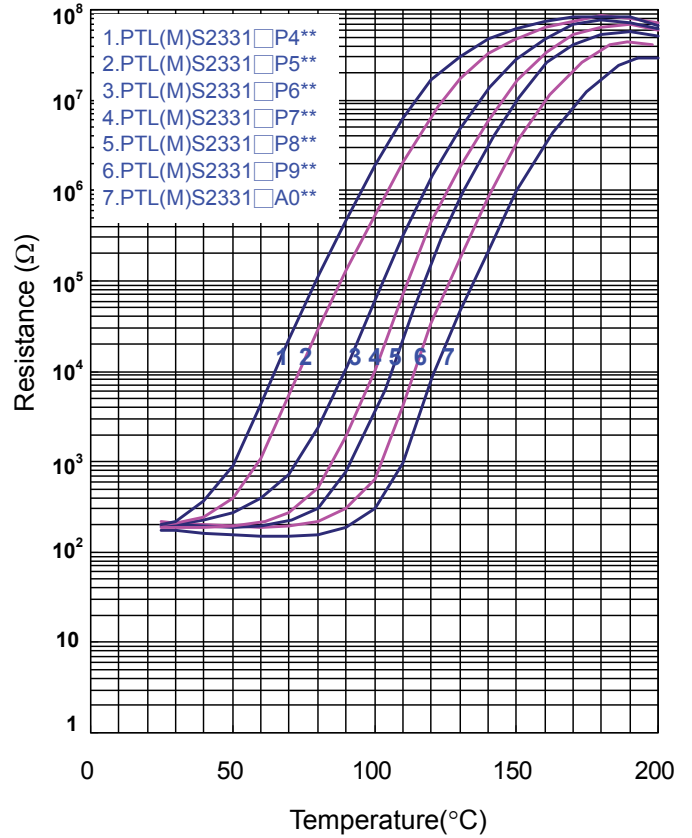
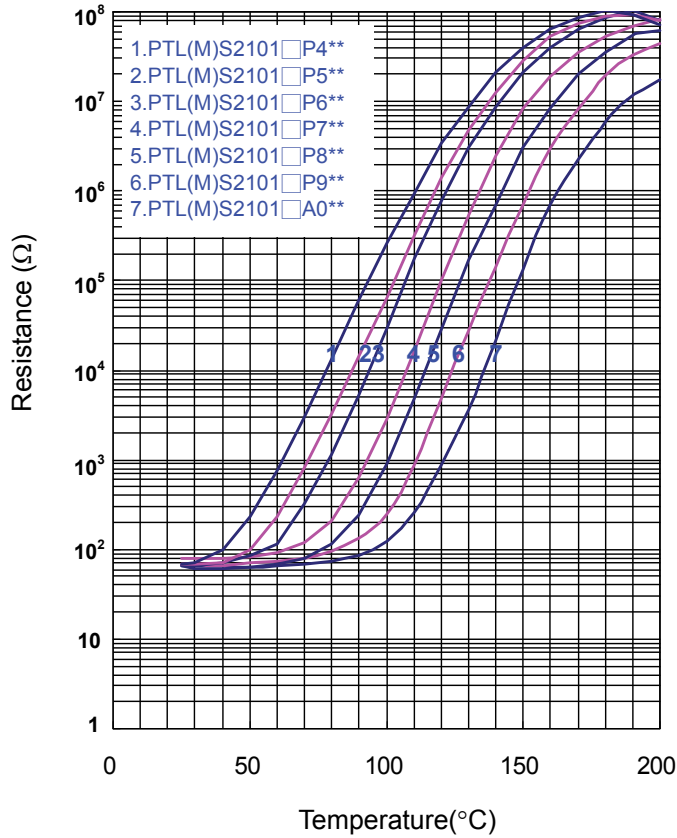

# Ceramic PTC Thermistor: PT Series

## Temperature Sensor



### ■ Soldering Recommendation

- Wave Flow Soldering Profile

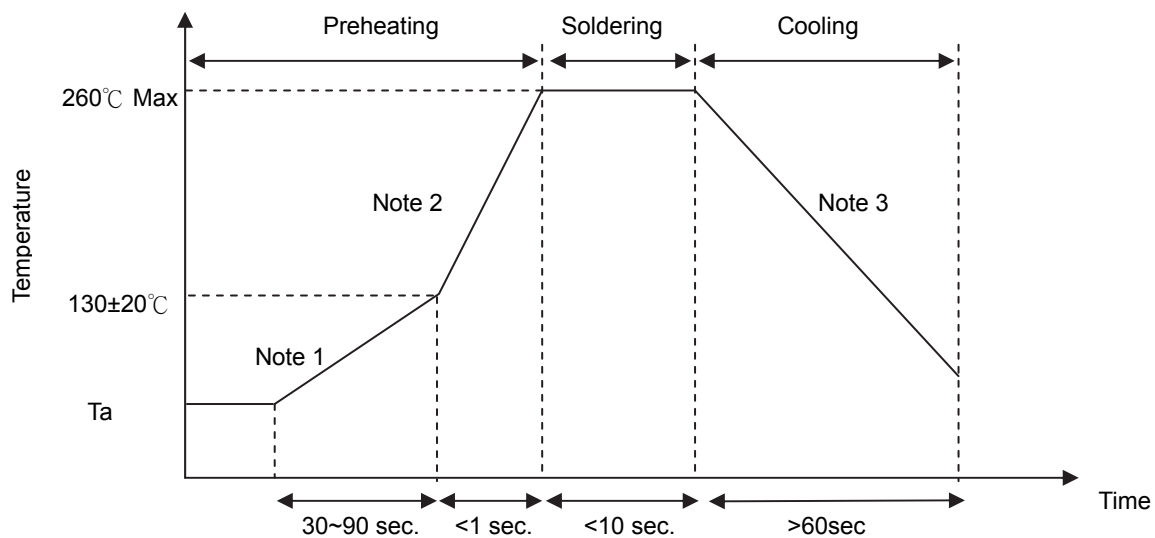

#### Note

1. (1~3°C)/sec.
2. Approx. 200°C/sec.
3. 5°C/sec. (Max)

### ■ Recommended Reworking Conditions With Soldering Iron

Item	Conditions
Temperature of Soldering Iron-tip	360°C (max.)
Soldering Time	3 sec (max.)
Distance from Coating	2 mm (min.)

# Ceramic PTC Thermistor: PT Series

## Temperature Sensor



### ■ Reliability Test

Item	Standard	Test Conditions and Methods	Specifications															
Robustness of Terminations	IEC 60738-1	Gradually apply the specified force and keep the unit fixed for 10±1 sec. <table style="margin-left: auto; margin-right: auto;"> <tr> <td style="text-align: center;">Terminal diameter (mm)</td> <td style="text-align: center;">Force T(N)</td> </tr> <tr> <td style="text-align: center;">0.35&lt;d≤0.5</td> <td style="text-align: center;">5.0</td> </tr> <tr> <td style="text-align: center;">0.5&lt;d≤0.8</td> <td style="text-align: center;">10.0</td> </tr> </table>	Terminal diameter (mm)	Force T(N)	0.35<d≤0.5	5.0	0.5<d≤0.8	10.0	$\Delta R_{25}/R_{25}$   ≤20% No visible damage									
Terminal diameter (mm)	Force T(N)																	
0.35<d≤0.5	5.0																	
0.5<d≤0.8	10.0																	
Solderability	IEC 60738-1	245±3 °C , 2±0.5 sec	At least 95% of terminal electrode is covered by new solder															
Resistance to Soldering Heat	IEC 60738-1	260±3 °C , 10±1 sec	$\Delta R_{25}/R_{25}$   ≤20% No visible damage															
Vibration	IEC 60738-1	Frequency range:10~55Hz Amplitude: 0.75mm or 98m/s <sup>2</sup> Direction: 3 mutually perpendicular directions Duration: 6hrs(3x2 hrs)	$\Delta R_{25}/R_{25}$   ≤20% No visible damage															
Shock	IEC 60738-1	Wave: half-sine $\Delta V$ : 1.0m/s Acceleration: 50 m/s <sup>2</sup> Pulse time: 30ms	$\Delta R_{25}/R_{25}$   ≤20% No visible damage															
Rapid Change of Temperature	IEC 60738-1	The thermal shock conditions shown below shall be repeated 5 cycles. <table border="1" style="margin-left: auto; margin-right: auto;"> <thead> <tr> <th>Step</th> <th>Temperature (°C)</th> <th>Period (minutes)</th> </tr> </thead> <tbody> <tr> <td style="text-align: center;">1</td> <td style="text-align: center;">-40 ± 5</td> <td style="text-align: center;">30 ± 3</td> </tr> <tr> <td style="text-align: center;">2</td> <td style="text-align: center;">Room temperature</td> <td style="text-align: center;">5 ± 3</td> </tr> <tr> <td style="text-align: center;">3</td> <td style="text-align: center;">85 ± 5</td> <td style="text-align: center;">30 ± 3</td> </tr> <tr> <td style="text-align: center;">4</td> <td style="text-align: center;">Room temperature</td> <td style="text-align: center;">5 ± 3</td> </tr> </tbody> </table>	Step	Temperature (°C)	Period (minutes)	1	-40 ± 5	30 ± 3	2	Room temperature	5 ± 3	3	85 ± 5	30 ± 3	4	Room temperature	5 ± 3	$\Delta R_{25}/R_{25}$   ≤20% No visible damage
Step	Temperature (°C)	Period (minutes)																
1	-40 ± 5	30 ± 3																
2	Room temperature	5 ± 3																
3	85 ± 5	30 ± 3																
4	Room temperature	5 ± 3																
Damp Heat, Steady State	IEC 60738-1	40±2°C , 90~95%RH, 1000±2 hrs	$\Delta R_{25}/R_{25}$   ≤20% No visible damage															
Climatic Sequence	IEC60738-1	Dry heat: Ts+25°C for 16 hrs Damp heat first cycle: 40°C , 95% R.H ,cycle time: 24 hrs Cold: 0°C for 2 hrs Damp heat (cyclic), remaining cycles: 5 cycles Test according to IEC60068-2-30	$\Delta R_{25}/R_{25}$   ≤20% No visible damage															
Endurance at Upper Category Temperature	IEC60738-1	Ts+25°C , for 1000±2hrs	$\Delta R_{25}/R_{25}$   ≤20% No visible damage															
Endurance at Maximum Operating Temperature and Maximum Voltage	IEC60738-1	Ts+25°C , Vmax, Imax for 1000±2 hrs	$\Delta R_{25}/R_{25}$   ≤20% No visible damage															
Insulation *1	CECC42000	100±15Vdc, 60±5 Sec	≥ 100MΩ															
Voltage Proof *1	CECC42000	1000±10Vrms, 60±5 Sec	No damage observed															

**Note:** \*1 : Available for PTM series only.

# Ceramic PTC Thermistor: PT Series

## Temperature Sensor



### ■ Packaging

#### ● Taping Specification (For straight lead)

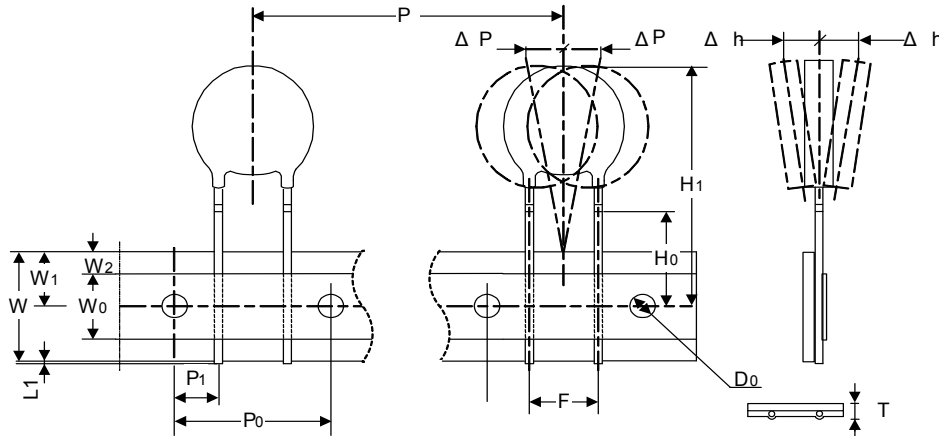

### ■ Parameter List

Index	Parameter	Nominal dimensions	Tolerance
F	Lead spacing	2.5	±1
P <sub>0</sub>	Sprocket hole pitch	12.7	±0.3
P <sub>1</sub>	Ordinate to adjacent component lead	5.10	±1
P	Device pitch	12.7	±1
H <sub>0</sub>	Abscissa to plane	18	±1
H <sub>1</sub>	Abscissa to top	32.5	Max.
W	Carrier tape width	18	±1
W <sub>0</sub>	Hold-down tape width	12	±1
W <sub>1</sub>	Sprocket hole position	9	±1
W <sub>2</sub>	Top distance between tape edges	3	3 Max.
ΔP	Body tape plane deviation	1	1 Max.
Δh	Body lateral deviation	2	2 Max.
L <sub>1</sub>	Lead protrusion	0.5	0.5 Max.
D <sub>0</sub>	Sprocket hole diameter	4	±0.2
T	Tape thickness	0.6	±0.2

**Note:** Taping specification is applied to PTL series only.

# Ceramic PTC Thermistor: PT Series Temperature Sensor



## ■ Quantity

### ● Bulk Packing

Type	Quantity (Pcs per bag)
PTL	500
PTM	200

### ● Reel Packing (For PTL Series only)

2,000 pcs per reel

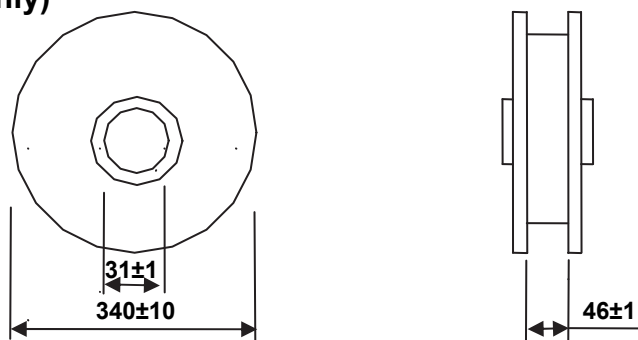

### ● Ammo packing (For PTL Series only)

1,500 pcs per box

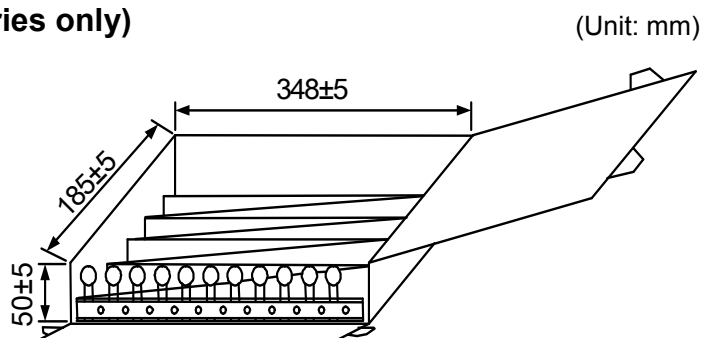

## ■ Warehouse Storage Conditions of Products

### ● Storage Conditions :

1. Storage Temperature :  $-10^{\circ}\text{C} \sim +40^{\circ}\text{C}$
2. Relative Humidity :  $\leq 75\% \text{RH}$
3. Keep away from corrosive atmosphere and sunlight.

### ● Period of Storage : 1 year

## ■ Usage

Please keep products away from the conditions mentioned below to avoid their characteristic deterioration and failure.

1. Corrosive gas or deoxidizing gas ( $\text{Cl}_2$ ,  $\text{H}_2\text{S}$ ,  $\text{NH}_3$ ,  $\text{SO}_x$ ,  $\text{NO}_x$  etc.)
2. Place in a vacuum or put pressure
3. Salt water, oil, solvent and chemical liquid
4. Flammable gas
5. Place in splashed water, or high humidity and dewing place
6. Other places similar to any conditions mentioned above