

Metal Oxide Varistor : TVT Series



Thermally Protected Varistor Series

■ Features

1. RoHS compliant
2. Halogen-free series are available
3. Two-Terminal or Three-Terminal thermally protected metal oxide varistor, Three-Terminal type is available for failure indication.
4. Body size: 14, 20 mm
5. Working voltage: 130Vac ~ 750Vac
6. Operating temperature range : -40°C ~ +85°C
Storage temperature range : -40°C ~ +110°C
7. Patent: US 7,453,681
8. Agency approval:
 - TVT14 and TVT20 Series: UL1449 3rd & cUL/ TUV/CQC
 - TVT25 and TVT34 Series: UL1449 3rd & cUL/ TUV
 - TVT32 Series: UL1449 3rd & cUL/ TUV
9. UL1449 3rd SPD Type: Type 4 Assemblies
10. Meets UL 1449 3rd 39.4 limited current abnormal over- voltage test.
11. TVT14 and TVT20 Series meet IEC 60950-1 Annex Q requirement
12. Suitable for wave flow soldering

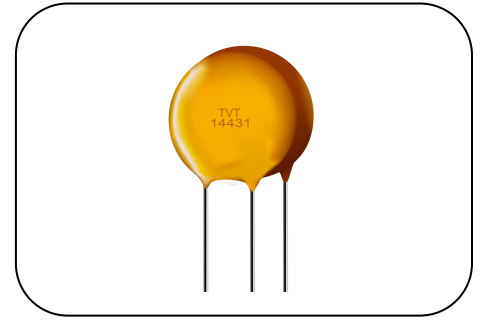

■ Recommended Applications

1. TVSS modules
2. Uninterruptible power supplies
3. Power supplies
4. Lighting products
5. Communication products
6. Smart meter
7. Photovoltaic industry

■ Part Number Code

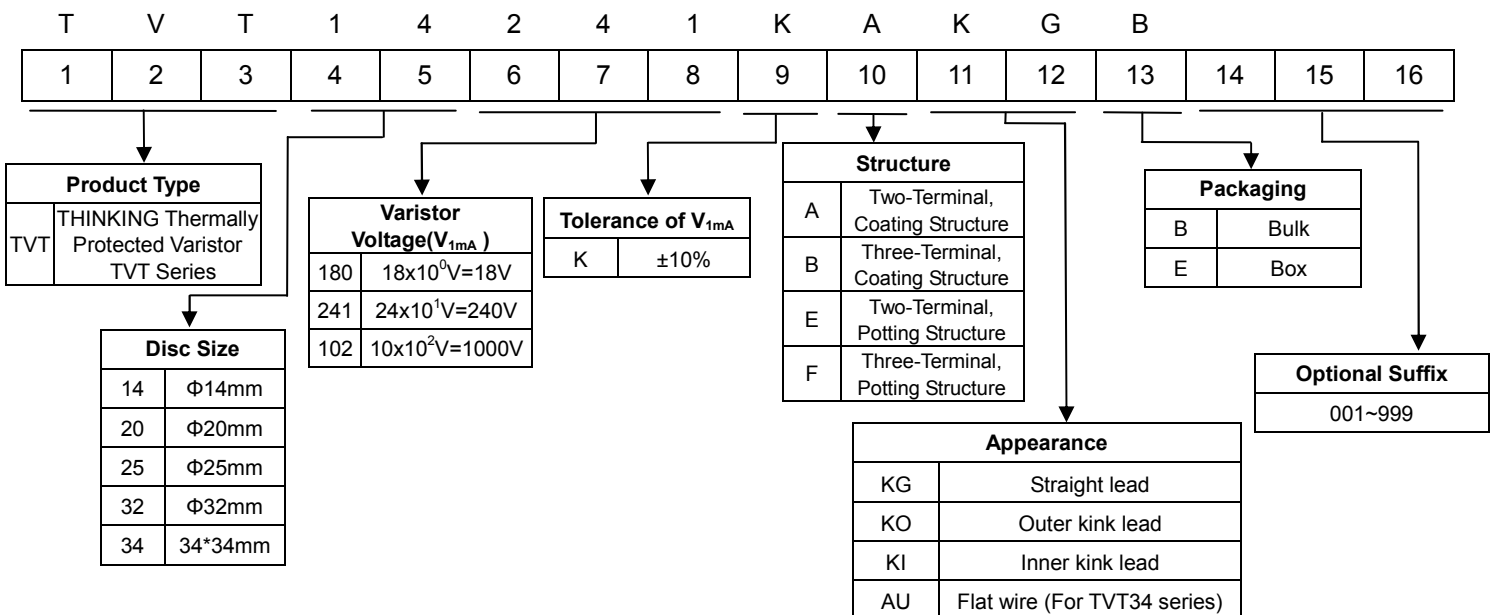

Metal Oxide Varistor : TVT Series



Thermally Protected Varistor Series

■ Structure and Dimensions

● TVT14 ~ TVT20 Series

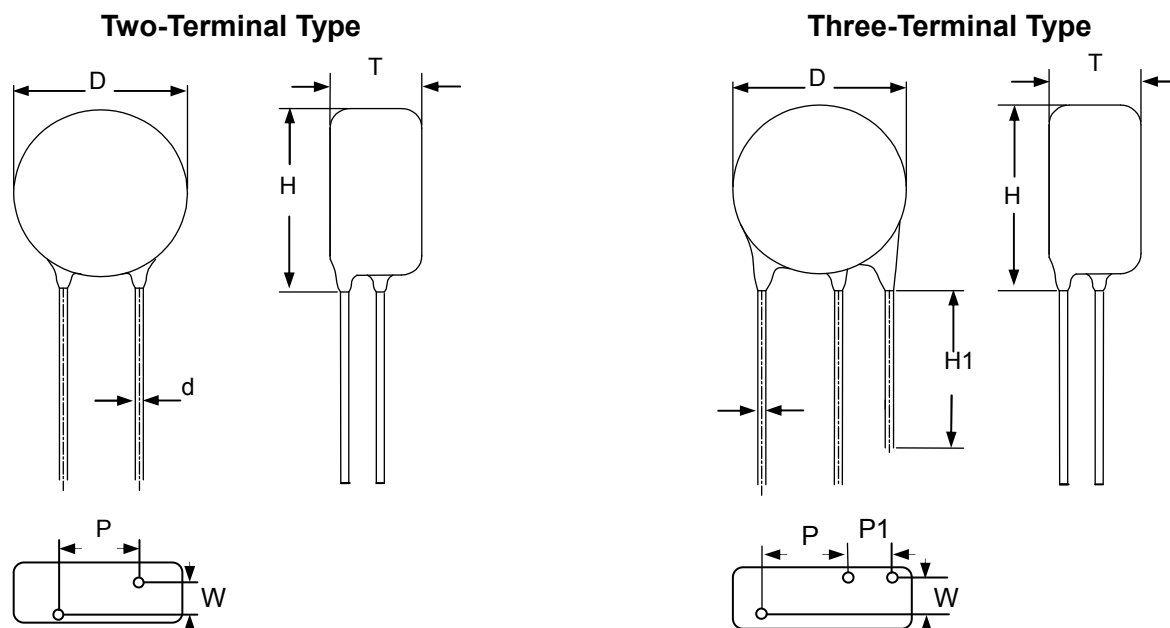

(Unit: mm)

Series	Lead Type	D	P	P1	H	H1	d	W	Tmax
TVT14201~122	Two-Terminal	15.5~18.5	7.5±1	--	18.5~24	--	0.8±0.05	Please Refer to Electrical Characteristics	
TVT14201~122	Three-Terminal	15.5~18.5	7.5±1	4.0~6.0	18.5~24	7.0~18	0.8±0.05		
TVT20201~681	Two-Terminal	19.5~23.5	7.5±1	--	21.5~27	--	0.8±0.05		
TVT20751~122							1.0±0.05		
TVT20201~681	Three-Terminal	19.5~23.5	7.5±1	4.0~6.0	21.5~27	12.5~18	0.8±0.05		
TVT20751~122							1.0±0.05		

Metal Oxide Varistor : TVT Series



Thermally Protected Varistor Series

● TVT25 ~ TVT32 Series

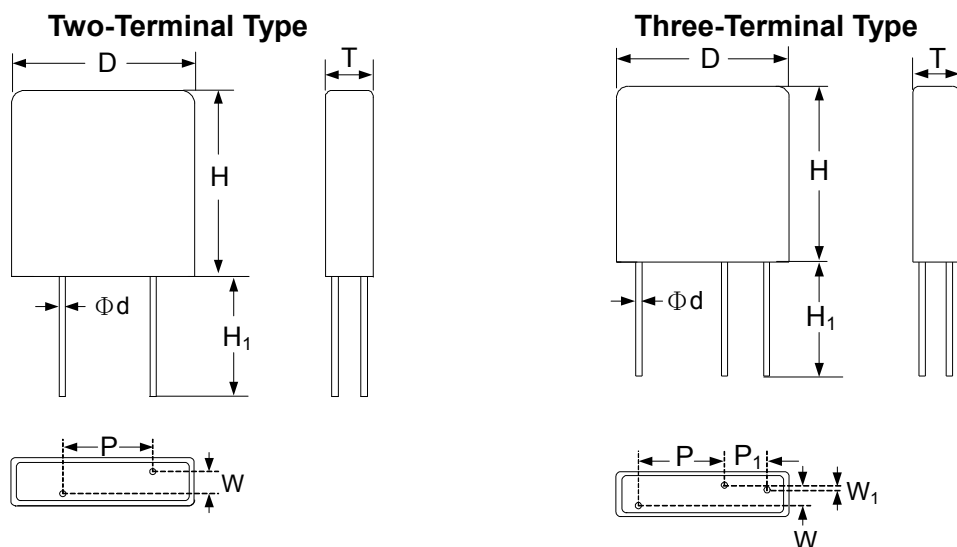

(Unit: mm)

Series	Lead Type	D±1.0	H±1.0	H1min	P±1.0	P1±1.0	d±0.05	W/W ₁	Tmax
TVT25	Two-Terminal	33.0	33.5	15	10.0	-----	1.0	Please Refer to Electrical Characteristics	
	Three-Terminal				10.0	5.0			

Series	Lead Type	D±1.0	H±1.0	H1min	P±1.5	P1±1.5	d±0.05	W/W ₁	Tmax
TVT32	Two-Terminal	40.0	42.0	15	15.0	-----	1.5	Please Refer to Electrical Characteristics	
	Three-Terminal				15.0	8.0			

● TVT34 Series

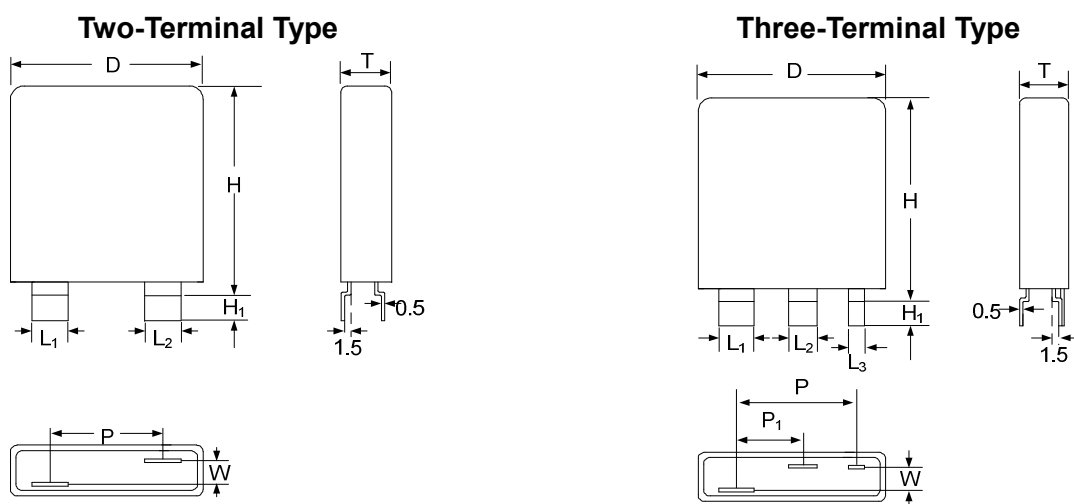

(Unit: mm)

Series	Type	D±1.0	Hmax	H1max.	P±2.0	P1±2.0	L1±0.1	L2±0.1	L3±0.1	W	Tmax
TVT34	Two-Terminal	40.0	42.0	8	21.5	-----	6.0	6.0	-----	Please Refer to Electrical Characteristics	
	Three-Terminal				23.5	11	6.0	5.0	3.0		

Metal Oxide Varistor : TVT Series

Thermally Protected Varistor Series



■ Electrical Characteristics

14mm Series

Part No.	Varistor Voltage (@1mA DC)	Max. Continuous Voltage		Max. Clamping Voltage (8/20 μ s)		Max. Surge Current (8/20 μ s)	Nominal Discharge Current ¹ (8/20 μ s)	Rated Power	Max. Energy (10/1000 μ s)	Reference Capacitance @1KHz	Dimension	
	V _{1mA}	V _{AC(rms)}	V _{DC}	V _P	I _P	I _{max}	I _n	P	W _{max}	C _p	T _{max}	W \pm 1.0
	(V)	(V)	(V)	(V)	(A)	(KA)	(KA)	(W)	(J)	(pF)	(mm)	
TVT14201	200 (180~220)	130	170	340	50	6	3	0.6	77	700	8.8	3.0
TVT14221	220 (198~242)	140	180	365	50	6	3	0.6	86	640	8.9	3.1
TVT14241	240 (216~264)	150	200	395	50	6	3	0.6	94	580	9.1	3.3
TVT14271	270 (243~297)	175	225	455	50	6	3	0.6	110	520	9.3	3.5
TVT14301	300 (270~330)	195	250	500	50	6	3	0.6	118	480	9.0	3.2
TVT14331	330 (297~363)	215	275	550	50	6	3	0.6	127	450	9.1	3.3
TVT14361	360 (324~396)	230	300	595	50	6	3	0.6	137	430	9.3	3.5
TVT14391	390 (351~429)	250	320	650	50	6	3	0.6	154	390	9.5	3.6
TVT14431	430 (387~473)	275	350	710	50	6	3	0.6	170	370	9.2	3.4
TVT14471	470 (423~517)	300	385	775	50	6	3	0.6	192	320	9.3	3.5
TVT14511	510 (459~561)	320	410	845	50	6	3	0.6	209	290	9.5	3.7
TVT14561	560 (504~616)	350	450	930	50	6	3	0.6	220	260	9.7	3.9
TVT14621	620 (558~682)	395	510	1025	50	6	3	0.6	231	240	10.0	4.1
TVT14681	680 (612~748)	420	560	1120	50	6	3	0.6	242	230	10.3	4.4
TVT14751	750 (675~825)	465	615	1240	50	6	3	0.6	247	220	10.6	4.7
TVT14781	780 (702~858)	485	640	1290	50	6	3	0.6	260	200	10.1	4.3
TVT14821	820 (738~902)	510	670	1355	50	6	3	0.6	270	180	10.2	4.5
TVT14911	910 (819~1001)	550	745	1500	50	6	3	0.6	280	170	10.6	4.8
TVT14951	950 (855~1045)	575	765	1570	50	6	3	0.6	290	160	10.7	4.9
TVT14102	1000 (900~1100)	625	825	1650	50	6	3	0.6	305	150	10.9	5.1
TVT14112	1100 (990~1210)	680	895	1815	50	6	3	0.6	340	140	11.2	5.4
TVT14122	1200 (1080~1320)	750	980	2000	50	6	--	0.6	350	130	11.6	5.8

Note:

*1: Nominal discharge current is the specification defined in UL 1449 3rd and use 8/20 μ s current waveform to test the varistor.

Metal Oxide Varistor : TVT Series



Thermally Protected Varistor Series

20mm Series

Part No.	Varistor Voltage (@1mA DC)	Max. Continuous Voltage		Max. Clamping Voltage (8/20 μ s)		Max. Surge Current (8/20 μ s)	Nominal Discharge Current ¹ (8/20 μ s)	Rated Power	Max. Energy (10/1000 μ s)	Reference Capacitance @1KHz	Dimension	
	V _{1mA}	V _{AC(rms)}	V _{DC}	V _P	I _P	I _{max}	I _n	P	W _{max}	C _p	T _{max}	W \pm 1.0
	(V)	(V)	(V)	(V)	(A)	(KA)	(KA)	(W)	(J)	(pF)	(mm)	
TVT20201	200 (180~220)	130	170	340	100	10	3	1.0	140	1460	10.2	3.0
TVT20221	220 (198~242)	140	180	365	100	10	3	1.0	155	1320	10.3	3.1
TVT20241	240 (216~264)	150	200	395	100	10	3	1.0	170	1200	10.5	3.3
TVT20271	270 (243~297)	175	225	455	100	10	3	1.0	190	1100	10.7	3.5
TVT20301	300 (270~330)	195	250	500	100	10	3	1.0	205	1000	10.4	3.2
TVT20331	330 (297~363)	215	275	550	100	10	3	1.0	215	950	10.5	3.3
TVT20361	360 (324~396)	230	300	595	100	10	3	1.0	225	900	10.7	3.5
TVT20391	390 (351~429)	250	320	650	100	10	3	1.0	240	800	10.9	3.6
TVT20431	430 (387~473)	275	350	710	100	10	3	1.0	270	700	10.6	3.4
TVT20471	470 (423~517)	300	385	775	100	10	3	1.0	350	620	10.7	3.5
TVT20511	510 (459~561)	320	410	845	100	10	3	1.0	386	530	10.9	3.7
TVT20561	560 (504~616)	350	450	930	100	10	3	1.0	400	480	11.1	3.9
TVT20621	620 (558~682)	395	510	1025	100	10	3	1.0	425	450	11.4	4.1
TVT20681	680 (612~748)	420	560	1120	100	10	3	1.0	455	440	11.7	4.4
TVT20751	750 (675~825)	465	615	1240	100	10	3	1.0	509	420	12.0	4.7
TVT20781	780 (702~858)	485	640	1290	100	10	3	1.0	515	400	11.5	4.3
TVT20821	820 (738~902)	510	670	1355	100	10	3	1.0	475	390	11.6	4.5
TVT20911	910 (819~1001)	550	745	1500	100	10	3	1.0	509	360	12.0	4.8
TVT20951	950 (855~1045)	575	765	1570	100	10	3	1.0	530	340	12.1	4.9
TVT20102	1000 (900~1100)	625	825	1650	100	10	3	1.0	560	330	12.3	5.1
TVT20112	1100 (990~1210)	680	895	1815	100	10	3	1.0	610	310	12.6	5.4
TVT20122	1200 (1080~1320)	750	980	2000	100	10	--	1.0	620	290	13.0	5.8

Note:
*1: Nominal discharge current is the specification defined in UL 1449 3rd and use 8/20 μ s current waveform to test the varistor.

Metal Oxide Varistor : TVT Series



Thermally Protected Varistor Series

25mm Series

Part No.	Varistor Voltage (@1mA DC)	Max. Continuous Voltage		Max. Clamping Voltage (8/20μs)		Max. Surge Current (8/20μs)	Nominal Discharge Current ¹ (8/20μs)	Rated Power	Max. Energy (10/1000μs)	Reference Capacitance @1KHz	Dimension		
	V _{1mA}	V _{AC(rms)}	V _{DC}	V _P	I _P	I _{max}	I _n	P	W _{max}	C _p	T _{max}	W1 ±1.0	W ±1.0
	(V)	(V)	(V)	(V)	(A)	(KA)	(KA)	(W)	(J)	(pF)	(mm)		
TVT25201	200 (180~220)	130	170	340	150	20	5	1.0	210	2200	15	1.9	5.6
TVT25221	220 (198~242)	140	180	360	150	20	5	1.0	230	2000			5.8
TVT25241	240 (216~264)	150	200	395	150	20	5	1.0	255	1900			6.0
TVT25271	270 (243~297)	175	225	455	150	20	5	1.0	285	1600			6.3
TVT25301	300 (270~330)	195	250	500	150	20	5	1.0	310	1500			5.8
TVT25331	330 (297~363)	215	275	550	150	20	5	1.0	325	1400			6.1
TVT25361	360 (324~396)	230	300	595	150	20	5	1.0	340	1300			6.3
TVT25391	390 (351~429)	250	320	650	150	20	5	1.0	360	1100			6.5
TVT25431	430 (387~473)	275	350	710	150	20	5	1.0	440	1000			5.7
TVT25471	470 (423~517)	300	385	775	150	20	5	1.0	490	950			5.8
TVT25511	510 (459~561)	320	410	845	150	20	5	1.0	530	900	6.0		
TVT25561	560 (504~616)	350	450	930	150	20	5	1.0	560	800	19	1.9	6.3
TVT25621	620 (558~682)	395	510	1020	150	20	5	1.0	590	700			6.6
TVT25681	680 (612~748)	420	560	1120	150	20	5	1.0	620	650			6.9
TVT25751	750 (675~825)	465	615	1235	150	20	5	1.0	630	600			7.2
TVT25781	780 (702~858)	485	640	1290	150	20	5	1.0	675	550			6.4
TVT25821	820 (738~902)	510	670	1355	150	20	5	1.0	690	520			6.5
TVT25911	910 (819~1001)	550	745	1500	150	20	5	1.0	715	500			6.8
TVT25951	950 (855~1045)	575	765	1570	150	20	5	1.0	740	450			7.0
TVT25102	1000 (900~1100)	625	825	1650	150	20	5	1.0	770	430			7.2
TVT25112	1100 (990~1210)	680	895	1815	150	20	5	1.0	840	400			7.5
TVT25122	1200 (1080~1320)	750	980	2000	150	20	--	1.0	910	380	7.8		

Note:

*1: Nominal discharge current is the specification defined in UL 1449 3rd and use 8/20μs current waveform to test the varistor.

Metal Oxide Varistor : TVT Series



Thermally Protected Varistor Series

32mm Series

Part No.	Varistor Voltage (@1mA DC)	Max. Continuous Voltage		Max. Clamping Voltage (8/20µs)		Max. Surge Current (8/20µs)	Nominal Discharge Current ¹ (8/20µs)	Rated Power	Max. Energy (10/1000µs)	Reference Capacitance @1KHz	Dimension	
	V _{1mA}	V _{AC(rms)}	V _{DC}	V _P	I _P	I _{max}	I _n	C _p	W _{max}	C _p	T _{max}	W±1.0
	(V)	(V)	(V)	(V)	(A)	(KA)	(KA)	(W)	(J)	(pF)	(mm)	
TVT32201	200 (180~220)	130	170	340	200	25	10	1.2	295	3900	16	6.2
TVT32221	220 (198~242)	140	180	360	200	25	10	1.2	315	3500		6.4
TVT32241	240 (216~264)	150	200	395	200	25	10	1.2	340	3300		6.6
TVT32271	270 (243~297)	175	225	455	200	25	10	1.2	360	2800		6.9
TVT32301	300 (270~330)	195	250	500	200	25	10	1.2	380	2600		6.4
TVT32331	330 (297~363)	215	275	550	200	25	10	1.2	400	2400		6.7
TVT32361	360 (324~396)	230	300	595	200	25	10	1.2	420	2200		6.9
TVT32391	390 (351~429)	250	320	650	200	25	10	1.2	465	2000		7.1
TVT32431	430 (387~473)	275	350	710	200	25	10	1.2	505	1800		6.3
TVT32471	470 (423~517)	300	385	775	200	25	10	1.2	570	1700		6.4
TVT32511	510 (459~561)	320	410	845	200	25	10	1.2	605	1600	6.6	
TVT32561	560 (504~616)	350	450	930	200	25	10	1.2	660	1400	20	6.9
TVT32621	620 (558~682)	395	510	1020	200	25	10	1.2	770	1250		7.2
TVT32681	680 (612~748)	420	560	1120	200	25	10	1.2	840	1150		7.5
TVT32751	750 (675~825)	465	615	1235	200	25	10	1.2	925	1100		7.8
TVT32781	780 (702~858)	485	640	1290	200	25	10	1.2	955	1050		7.0
TVT32821	820 (738~902)	510	670	1355	200	25	10	1.2	770	950		7.1
TVT32911	910 (819~1001)	550	745	1500	200	25	10	1.2	870	900		7.4
TVT32951	950 (855~1045)	575	765	1570	200	25	10	1.2	925	850		7.6
TVT32102	1000 (900~1100)	625	825	1650	200	25	10	1.2	965	800		7.8
TVT32112	1100 (990~1210)	680	895	1815	200	25	10	1.2	1065	750		8.1
TVT32122	1200 (1080~1320)	750	980	2000	200	25	--	1.2	1120	650	8.4	

Note:

*1: Nominal discharge current is the specification defined in UL 1449 3rd and use 8/20µs current waveform to test the varistor.

Metal Oxide Varistor : TVT Series



Thermally Protected Varistor Series

34*34mm Series

Part No.	Varistor Voltage (@1mA DC)	Max. Continuous Voltage		Max. Clamping Voltage (8/20μs)		Max. Surge Current (8/20μs)	Nominal Discharge Current ¹ (8/20μs)	Rated Power	Max. Energy (10/1000μs)	Reference Capacitance @1KHz	Dimension	
	V _{1mA}	V _{AC(rms)}	V _{DC}	V _P	I _P	I _{max}	I _n	P	W _{max}	C _p	T _{max}	W±1.0
	(V)	(V)	(V)	(V)	(A)	(KA)	(KA)	(W)	(J)	(pF)	(mm)	
TVT34201	200 (180~220)	130	170	340	300	40	20	1.4	435	5600	16	6.2
TVT34221	220 (198~242)	140	180	360	300	40	20	1.4	480	5000		6.4
TVT34241	240 (216~264)	150	200	395	300	40	20	1.4	505	4800		6.6
TVT34271	270 (243~297)	175	225	455	300	40	20	1.4	560	4100		6.9
TVT34301	300 (270~330)	195	250	500	300	40	20	1.4	590	3800		6.4
TVT34331	330 (297~363)	215	275	550	300	40	20	1.4	620	3500		6.7
TVT34361	360 (324~396)	230	300	595	300	40	20	1.4	645	3200		6.9
TVT34391	390 (351~429)	250	320	650	300	40	20	1.4	690	2800		7.1
TVT34431	430 (387~473)	275	350	710	300	40	20	1.4	770	2600		6.3
TVT34471	470 (423~517)	300	385	775	300	40	20	1.4	835	2400		6.4
TVT34511	510 (459~561)	320	410	845	300	40	20	1.4	900	2300		6.6
TVT34561	560 (504~616)	350	450	930	300	40	20	1.4	995	2000	20	6.9
TVT34621	620 (558~682)	395	510	1020	300	40	20	1.4	1120	1800		7.2
TVT34681	680 (612~748)	420	560	1120	300	40	20	1.4	1275	1700		7.5
TVT34751	750 (675~825)	465	615	1235	300	40	20	1.4	1400	1600		7.8
TVT34781	780 (702~858)	485	640	1290	300	40	20	1.4	1445	1500		7.0
TVT34821	820 (738~902)	510	670	1355	300	40	20	1.4	1205	1400		7.1
TVT34911	910 (819~1001)	550	745	1500	300	40	20	1.4	1345	1300		7.4
TVT34951	950 (855~1045)	575	765	1570	300	40	20	1.4	1400	1200		7.6
TVT34102	1000 (900~1100)	625	825	1650	300	40	20	1.4	1470	1150		7.8
TVT34112	1100 (990~1210)	680	895	1815	300	40	20	1.4	1610	1050		8.1
TVT34122	1200 (1080~1320)	750	980	2000	300	40	--	1.4	1750	950		8.4

Note:



*1: Nominal discharge current is the specification defined in UL 1449 3rd and use 8/20μs current waveform to test the varistor.

Metal Oxide Varistor : TVT Series

Thermally Protected Varistor Series



■ Safety Approvals

Part No.	Agency				
					
	UL1449 3 rd & cUL: E314979	J 50179371	IEC60950-1 2 nd Annex Q	GB/T 10193-1997 GB/T 10194-1997	GB 4943.1-2011 GB 8898-2011
	CQC13001104230				
TVT14201-□	√	√	√	√	
TVT14221-□	√	√	√	√	
TVT14241-□	√	√	√	√	
TVT14271-□	√	√	√	√	
TVT14301-□	√	√	√	√	
TVT14331-□	√	√	√	√	
TVT14361-□	√	√	√	√	
TVT14391-□	√	√	√	√	
TVT14431-□	√	√	√	√	√
TVT14471-□	√	√	√	√	√
TVT14511-□	√	√	√	√	√
TVT14561-□	√	√	√	√	√
TVT14621-□	√	√	√	√	√
TVT14681-□	√	√	√	√	√
TVT14751-□	√	√	√	√	√
TVT14781-□	√	√	√	√	√
TVT14821-□	√	√	√	√	√
TVT14911-□	√	√	√	√	√
TVT14951-□	√	√	√	√	√
TVT14102-□	√	√	√	√	√
TVT14112-□	√	√	√	√	√
TVT14122-□		√	√	√	√



□ is the code for Two -Terminal or Three -Terminal type.

Metal Oxide Varistor : TVT Series

Thermally Protected Varistor Series



■ Safety Approvals

Part No.	Agency				
					
	UL1449 3 rd & cUL: E314979	J 50179371	IEC60950-1 2 nd Annex Q	GB/T 10193-1997 GB/T 10194-1997	GB 4943.1-2011 GB 8898-2011
				CQC13001104230	
TVT20201-□	√	√	√	√	
TVT20221-□	√	√	√	√	
TVT20241-□	√	√	√	√	
TVT20271-□	√	√	√	√	
TVT20301-□	√	√	√	√	
TVT20331-□	√	√	√	√	
TVT20361-□	√	√	√	√	
TVT20391-□	√	√	√	√	
TVT20431-□	√	√	√	√	√
TVT20471-□	√	√	√	√	√
TVT20511-□	√	√	√	√	√
TVT20561-□	√	√	√	√	√
TVT20621-□	√	√	√	√	√
TVT20681-□	√	√	√	√	√
TVT20751-□	√	√	√	√	√
TVT20781-□	√	√	√	√	√
TVT20821-□	√	√	√	√	√
TVT20911-□	√	√	√	√	√
TVT20951-□	√	√	√	√	√
TVT20102-□	√	√	√	√	√
TVT20112-□	√	√	√	√	√
TVT20122-□		√	√	√	√



□ is the code for Two -Terminal or Three -Terminal type.



Metal Oxide Varistor : TVT Series

Thermally Protected Varistor Series



■ Safety Approvals

Part No.	Agency	
		
	UL1449 3 rd & cUL: E314979	J 50226398
TVT25201-□	√	√
TVT25221-□	√	√
TVT25241-□	√	√
TVT25271-□	√	√
TVT25301-□	√	√
TVT25331-□	√	√
TVT25361-□	√	√
TVT25391-□	√	√
TVT25431-□	√	√
TVT25471-□	√	√
TVT25511-□	√	√
TVT25561-□	√	√
TVT25621-□	√	√
TVT25681-□	√	√
TVT25751-□	√	√
TVT25781-□	√	√
TVT25821-□	√	√
TVT25911-□	√	√
TVT25951-□	√	√
TVT25102-□	√	√
TVT25112-□	√	√
TVT25122-□		√

Part No.	Agency	
		
	UL1449 3 rd & cUL: E314979	J 50226398
TVT32201-□	√	√
TVT32221-□	√	√
TVT32241-□	√	√
TVT32271-□	√	√
TVT32301-□	√	√
TVT32331-□	√	√
TVT32361-□	√	√
TVT32391-□	√	√
TVT32431-□	√	√
TVT32471-□	√	√
TVT32511-□	√	√
TVT32561-□	√	√
TVT32621-□	√	√
TVT32681-□	√	√
TVT32751-□	√	√
TVT32781-□	√	√
TVT32821-□	√	√
TVT32911-□	√	√
TVT32951-□	√	√
TVT32102-□	√	√
TVT32112-□	√	√
TVT32122-□		√



□ is the code for Two -Terminal or Three -Terminal type.

Metal Oxide Varistor : TVT Series

Thermally Protected Varistor Series



■ Safety Approvals

Part No.	Agency	
		
	UL1449 3 rd & cUL: E314979	J 50226398
TVT34201-□	√	√
TVT34221-□	√	√
TVT34241-□	√	√
TVT34271-□	√	√
TVT34301-□	√	√
TVT34331-□	√	√
TVT34361-□	√	√
TVT34391-□	√	√
TVT34431-□	√	√
TVT34471-□	√	√
TVT34511-□	√	√
TVT34561-□	√	√
TVT34621-□	√	√
TVT34681-□	√	√
TVT34751-□	√	√
TVT34781-□	√	√
TVT34821-□	√	√
TVT34911-□	√	√
TVT34951-□	√	√
TVT34102-□	√	√
TVT34112-□	√	√
TVT34122-□		√

□ is the code for Two -Terminal or Three -Terminal type.

Metal Oxide Varistor : TVT Series



Thermally Protected Varistor Series

Power Derating Curve

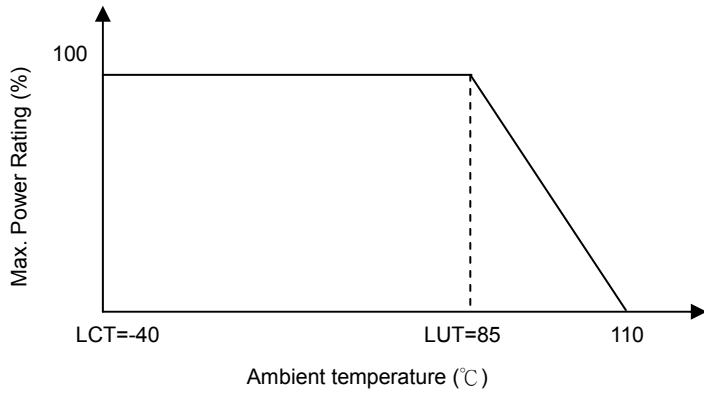

Surge Current Standard Waveform

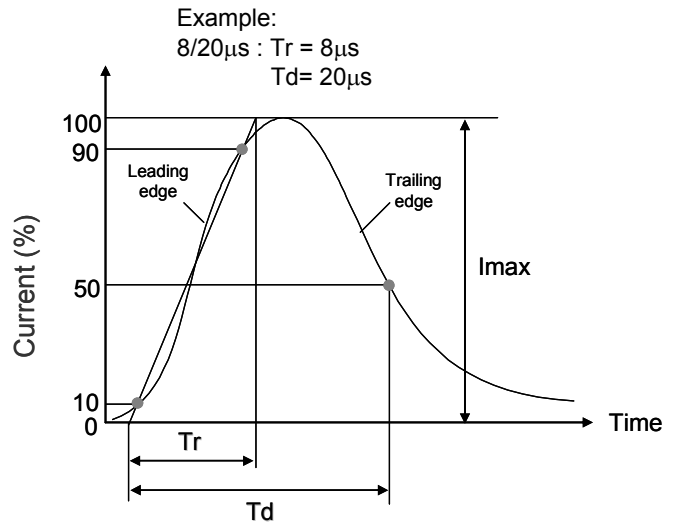

Lead Configuration

Two -Terminal Type

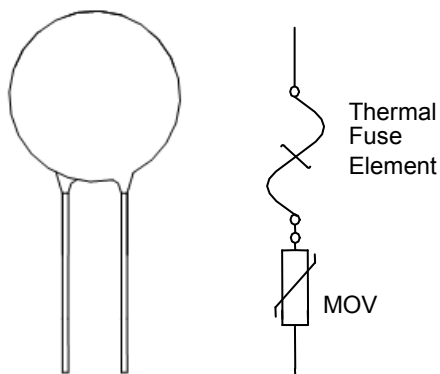

Three -Terminal Type

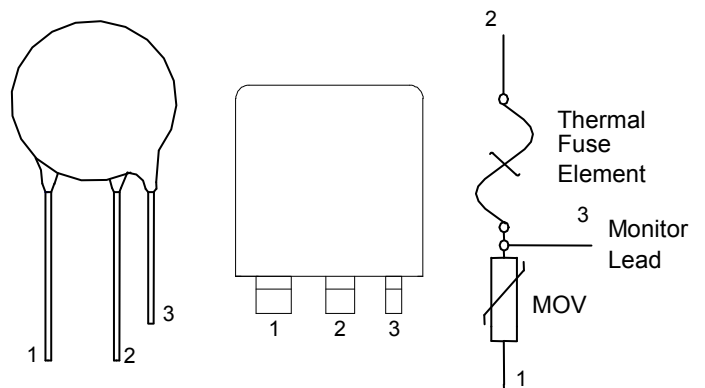

Metal Oxide Varistor : TVT Series



Thermally Protected Varistor Series

■ Typical Application Circuit

Signal Phase: Line to Line

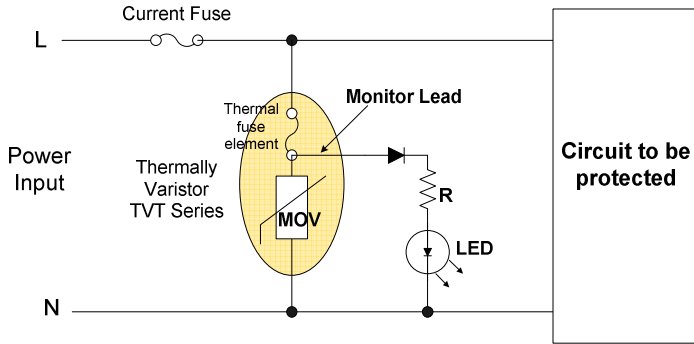

Signal Phase: Line to Line & Line to Ground

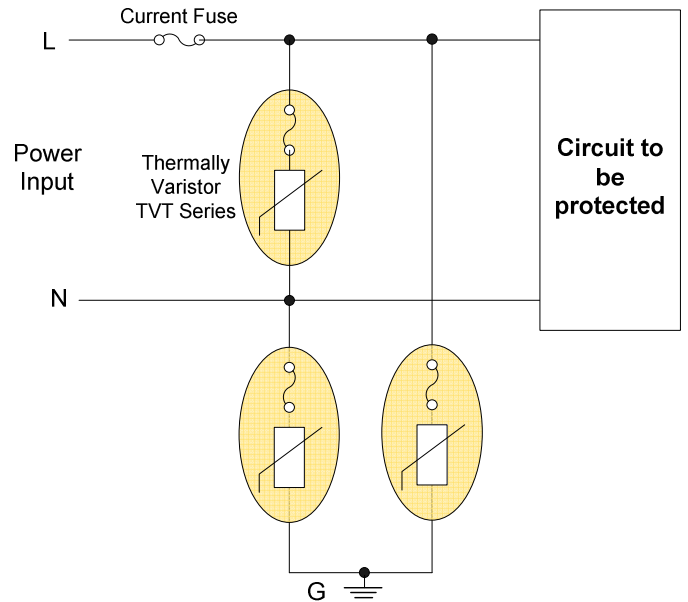

Three Phase: Line to Line & Line to Ground

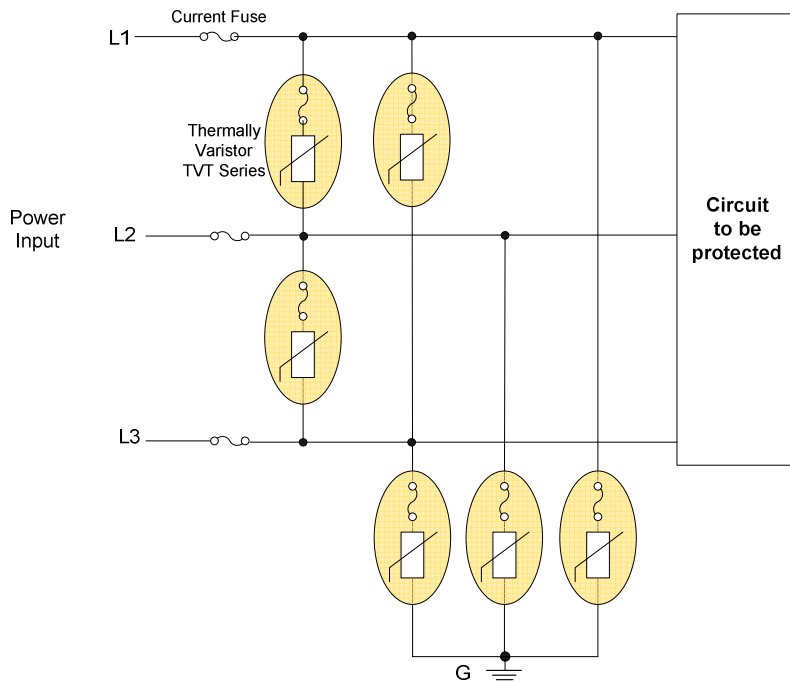

Metal Oxide Varistor : TVT Series



Thermally Protected Varistor Series

Max. Surge Current Derating Curves

TVT14201 ~ TVT14112

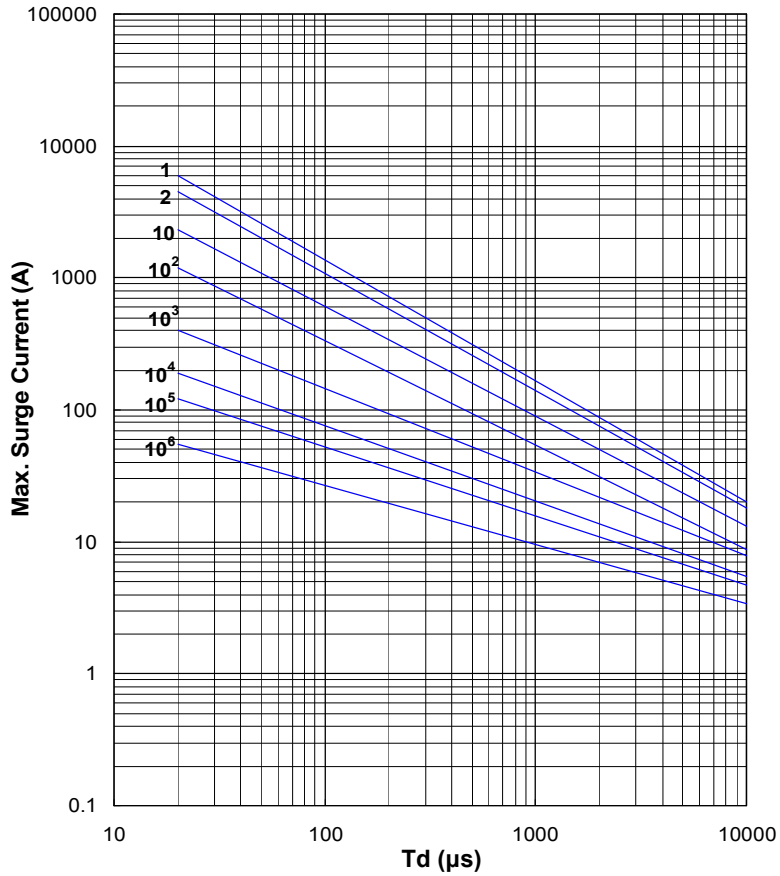

TVT20201 ~ TVT20112

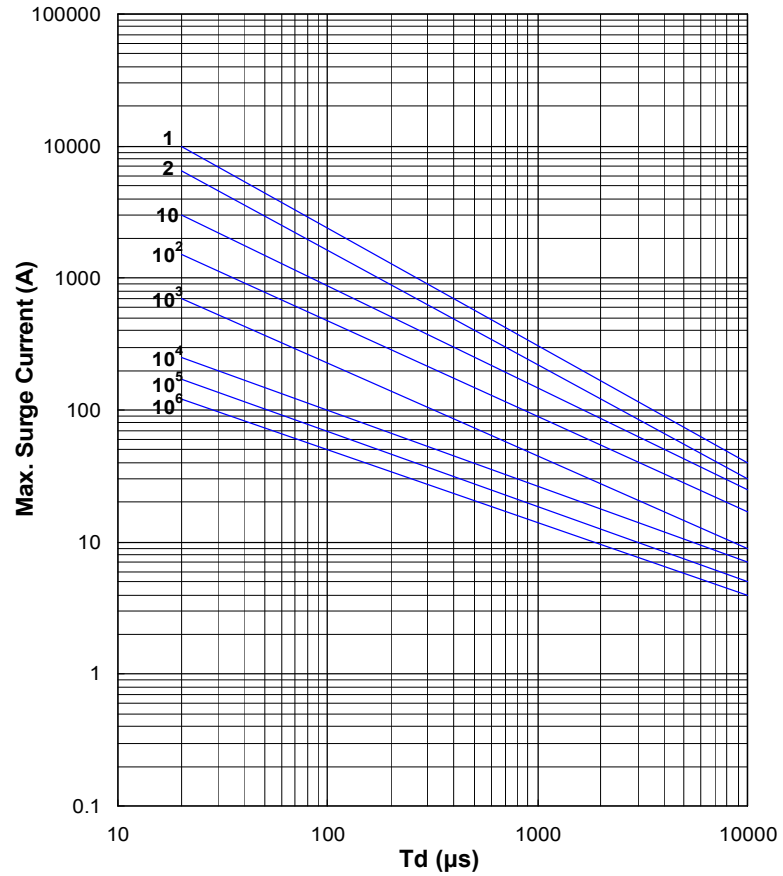

TVT25201 ~ TVT25122

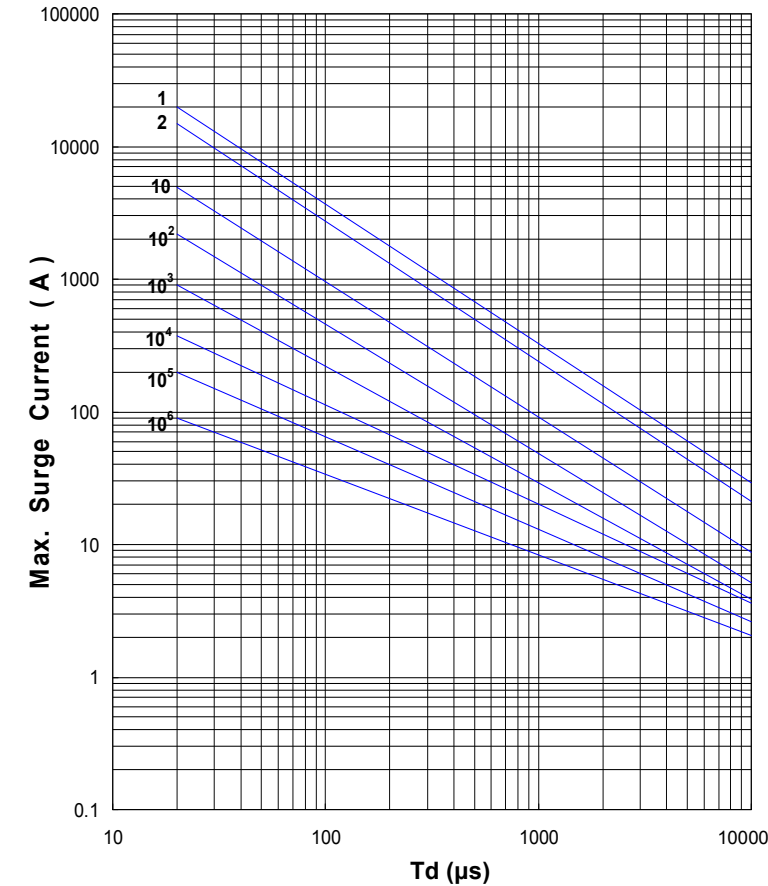

TVT32201 ~ TVT32122

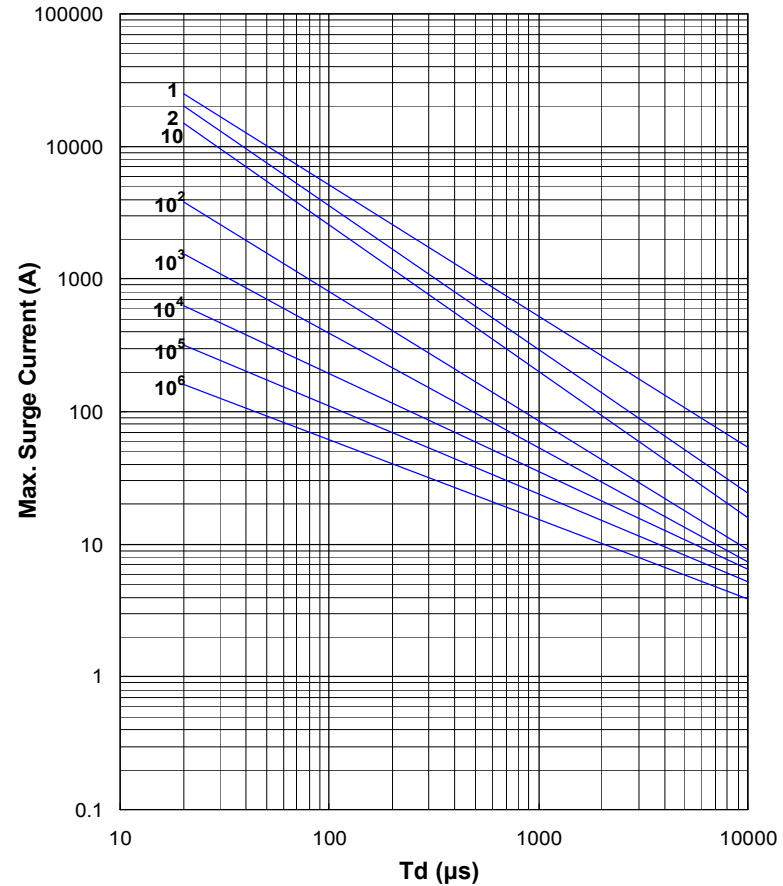

Metal Oxide Varistor : TVT Series

Thermally Protected Varistor Series



Max. Surge Current Derating Curves

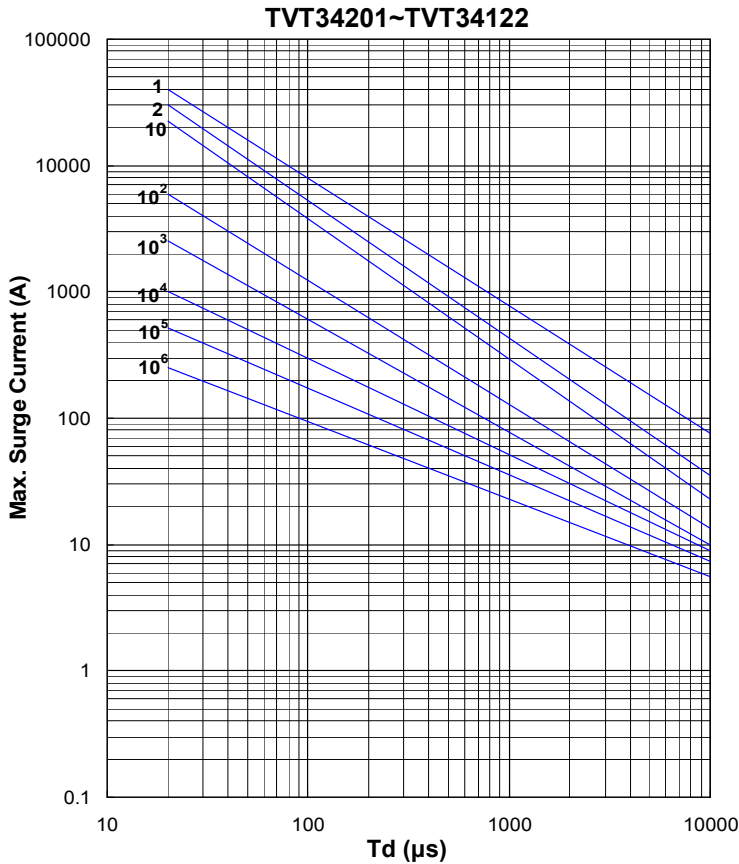

Max. Leakage Current and Max. Clamping Voltage Curves

Max. Leakage Current and Max. Clamping Voltage Curves (TVT14201 ~ TVT14122)

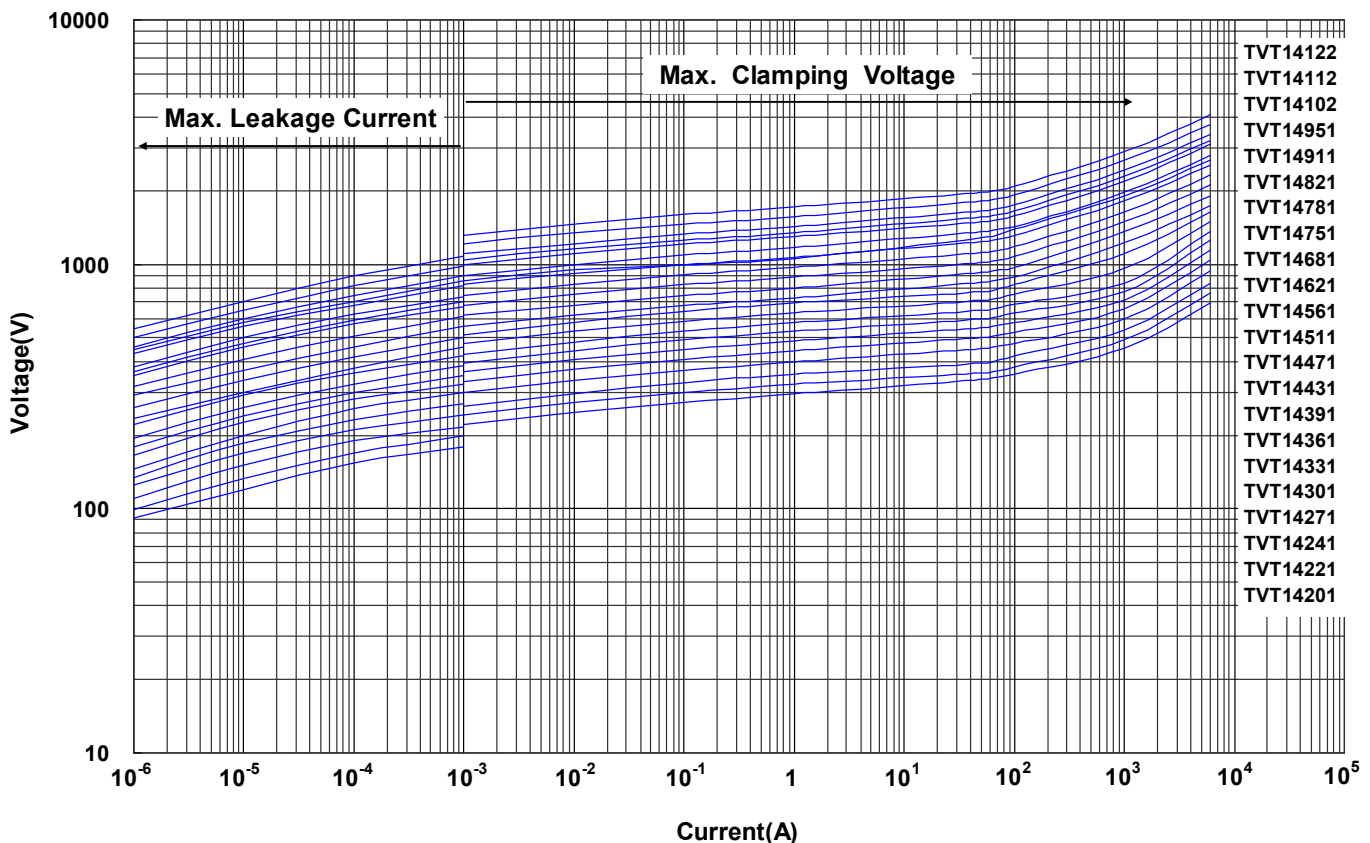

Metal Oxide Varistor : TVT Series



Thermally Protected Varistor Series

Max. Leakage Current and Max. Clamping Voltage Curves

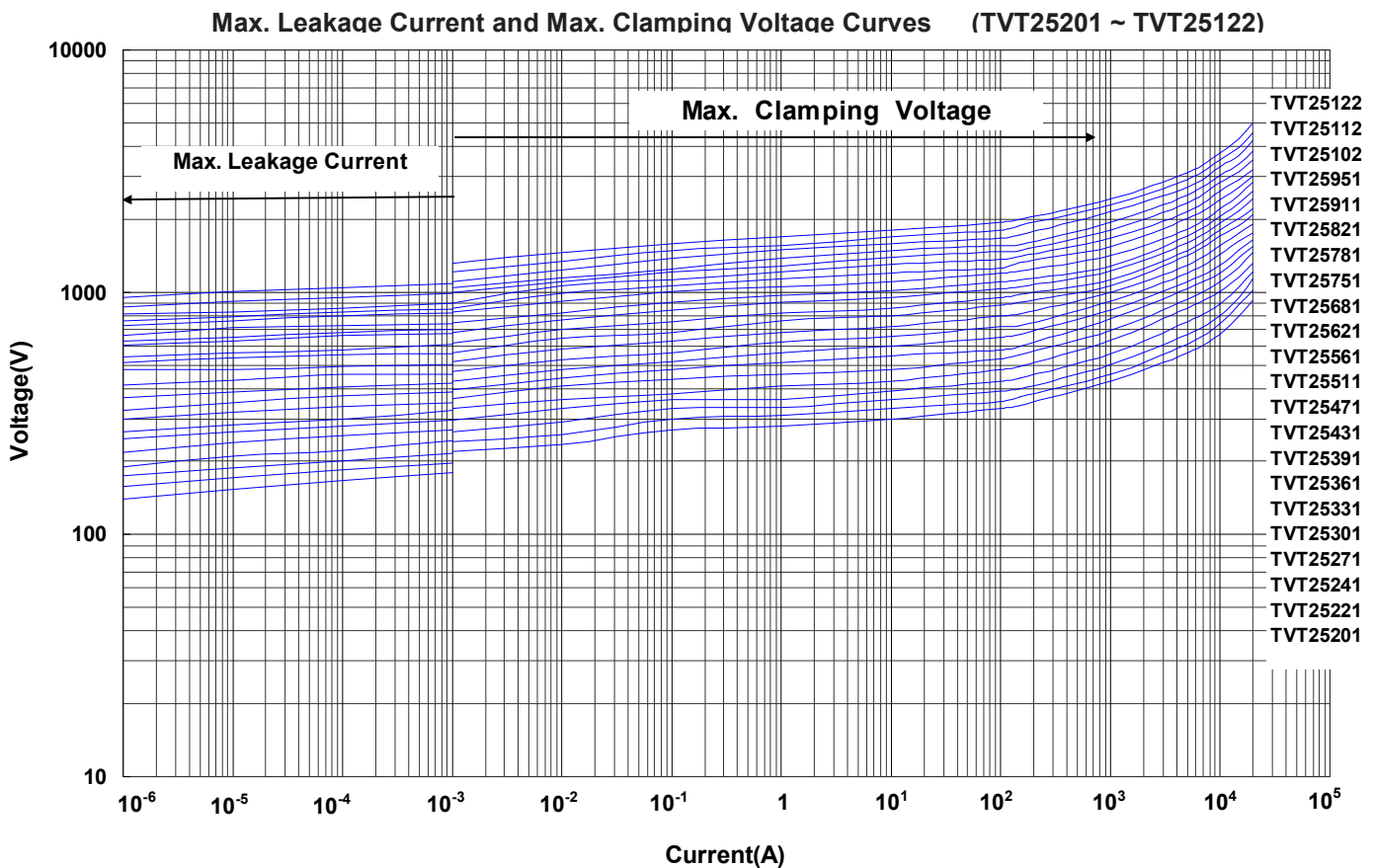
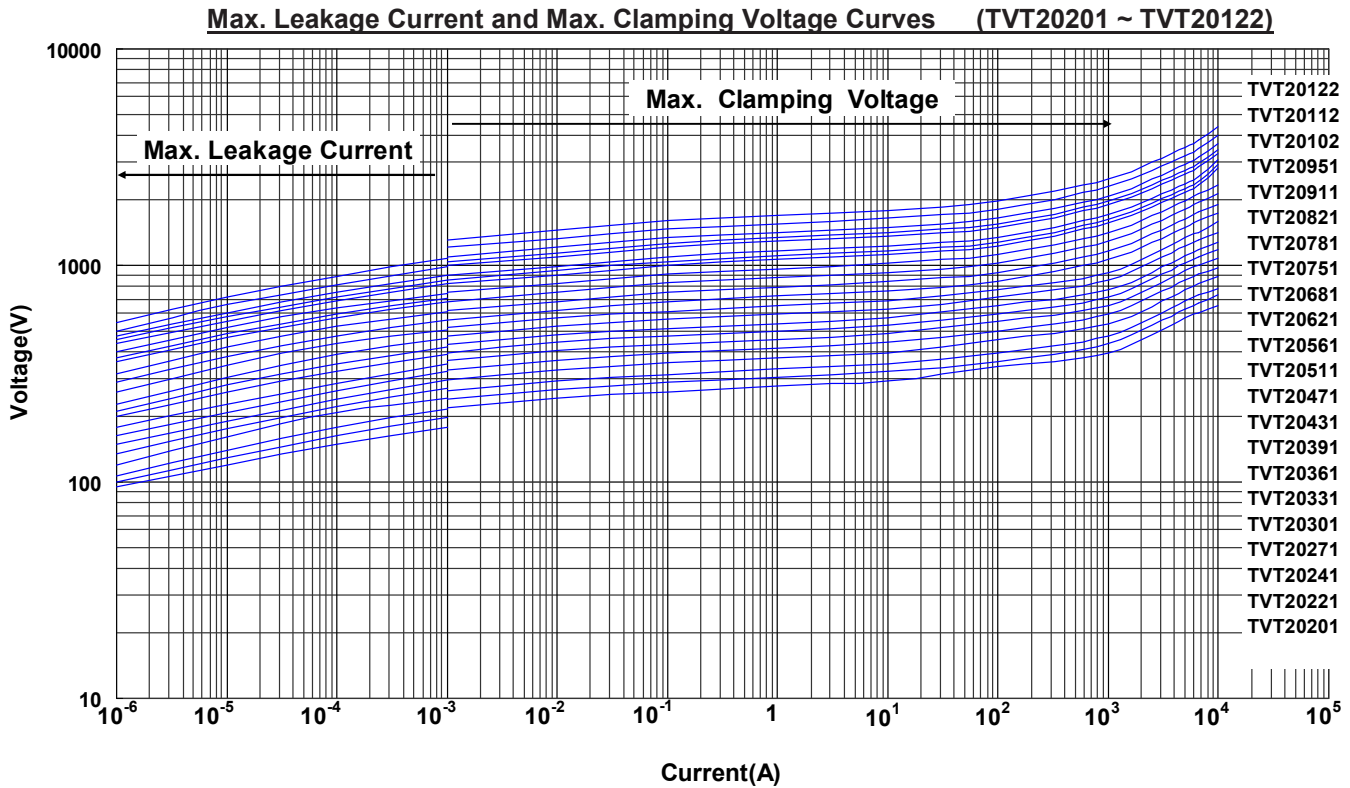

Metal Oxide Varistor : TVT Series

Thermally Protected Varistor Series



Max. Leakage Current and Max. Clamping Voltage Curves

Max. Leakage Current and Max. Clamping Voltage Curves (TVT32201 ~ TVT32122)

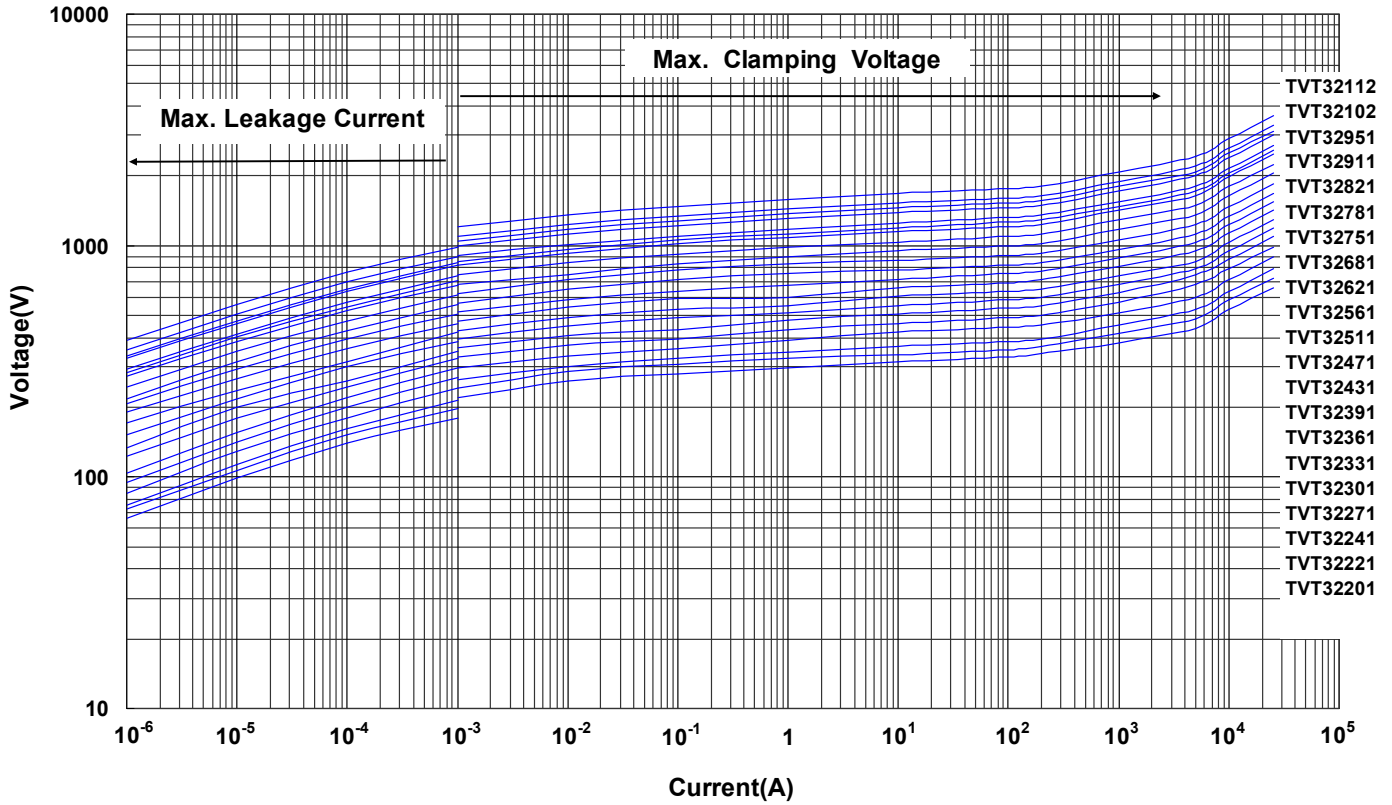

Max. Leakage Current and Max. Clamping Voltage Curves (TVT34201 ~ TVT34122)

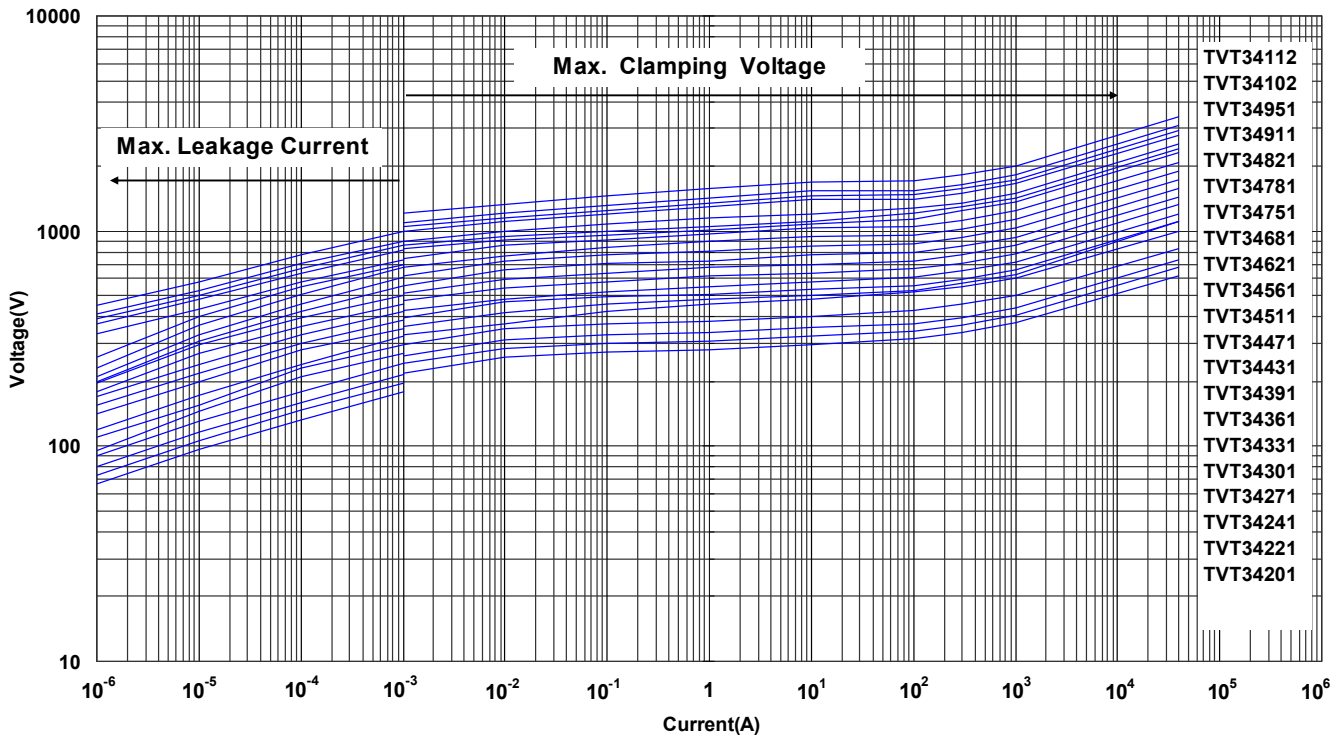

Metal Oxide Varistor : TVT Series



Thermally Protected Varistor Series

■ Soldering Recommendation

● Wave Soldering Profile

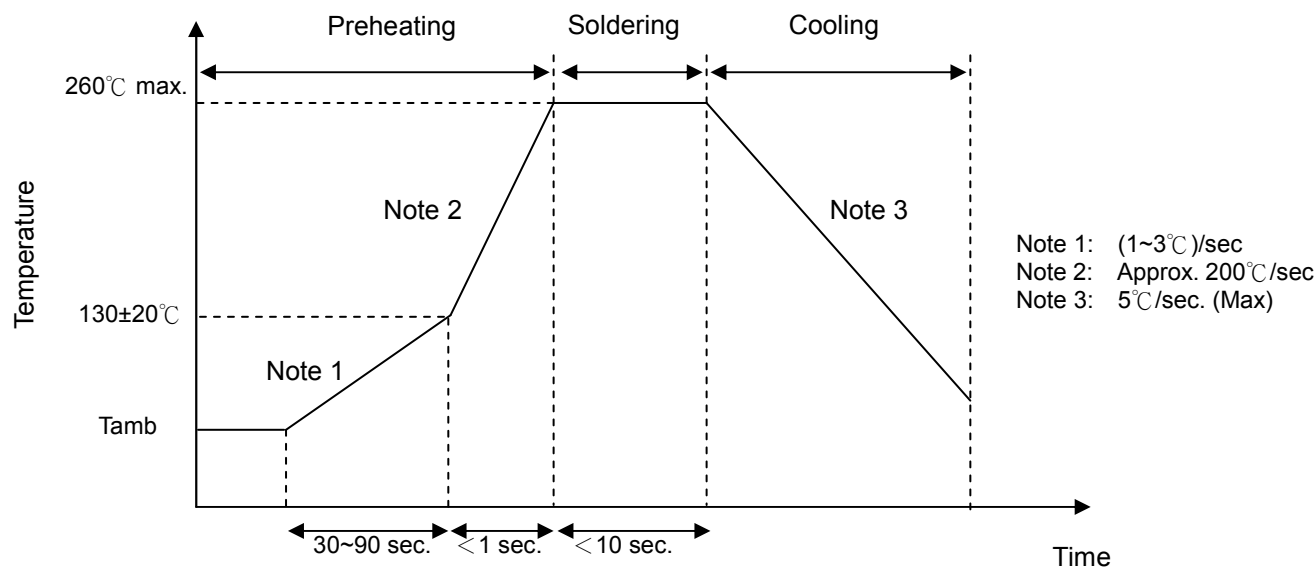

● Recommended Reworking Conditions With Soldering Iron

Item	Conditions
Temperature of Soldering Iron-tip	360°C (max.)
Soldering Time	3 sec (max.)
Distance from Varistor	2 mm (min.)

Metal Oxide Varistor : TVT Series



Thermally Protected Varistor Series

■ Reliability

Item	Standard	Test Conditions / Methods	Specifications															
Tensile Strength of Terminals	IEC 60068-2-21	<p>Gradually apply the specified force and keep the unit fixed for 10±1 sec.</p> <table border="1"> <thead> <tr> <th>Terminal diameter (mm)</th> <th>Terminal cross-sectional area (mm²)</th> <th>Force (Kg)</th> </tr> </thead> <tbody> <tr> <td>0.5<d≤0.8</td> <td>0.2<S≤0.5</td> <td>1.0</td> </tr> <tr> <td>0.8<d≤1.25</td> <td>0.5<S≤1.2</td> <td>2.0</td> </tr> <tr> <td>1.25<d</td> <td>1.2<S</td> <td>4.0</td> </tr> </tbody> </table>	Terminal diameter (mm)	Terminal cross-sectional area (mm ²)	Force (Kg)	0.5<d≤0.8	0.2<S≤0.5	1.0	0.8<d≤1.25	0.5<S≤1.2	2.0	1.25<d	1.2<S	4.0	$ \Delta V_{1mA}/V_{1mA} \leq 5\%$ No visible damage			
Terminal diameter (mm)	Terminal cross-sectional area (mm ²)	Force (Kg)																
0.5<d≤0.8	0.2<S≤0.5	1.0																
0.8<d≤1.25	0.5<S≤1.2	2.0																
1.25<d	1.2<S	4.0																
Bending Strength of Terminals	IEC 60068-2-21	<p>Hold specimen and apply the force specified below to each lead. Bend the specimen to 90°, and then return to the original position. Repeat the procedure in the opposite direction.</p> <table border="1"> <thead> <tr> <th>Terminal diameter (mm)</th> <th>Terminal cross-sectional area (mm²)</th> <th>Force (Kg)</th> </tr> </thead> <tbody> <tr> <td>0.5<d≤0.8</td> <td>0.2<S≤0.5</td> <td>0.5</td> </tr> <tr> <td>0.8<d≤1.25</td> <td>0.5<S≤1.2</td> <td>1.0</td> </tr> <tr> <td>1.25<d</td> <td>1.2<S</td> <td>2.0</td> </tr> </tbody> </table>	Terminal diameter (mm)	Terminal cross-sectional area (mm ²)	Force (Kg)	0.5<d≤0.8	0.2<S≤0.5	0.5	0.8<d≤1.25	0.5<S≤1.2	1.0	1.25<d	1.2<S	2.0	$ \Delta V_{1mA}/V_{1mA} \leq 5\%$ No visible damage			
Terminal diameter (mm)	Terminal cross-sectional area (mm ²)	Force (Kg)																
0.5<d≤0.8	0.2<S≤0.5	0.5																
0.8<d≤1.25	0.5<S≤1.2	1.0																
1.25<d	1.2<S	2.0																
Vibration	IEC 60068-2-6	Frequency range: 10 ~ 55 Hz Amplitude: 0.75mm or 98 m/s ² Direction: 3 mutually perpendicular directions, 2 hrs each.	$ \Delta V_{1mA}/V_{1mA} \leq 5\%$ No visible damage															
Solderability	IEC 60068-2-20	245±3°C , 3±0.3 sec	At least 95% of terminal electrode is covered by new solder															
Resistance to Soldering Heat	IEC 60068-2-20	260±3°C , 10±1 sec	$ \Delta V_{1mA}/V_{1mA} \leq 5\%$ No visible damage															
High Temperature Storage	IEC 60068-2-2	110±5°C x 1000± 24 hrs	$ \Delta V_{1mA}/V_{1mA} \leq 5\%$ No visible damage															
Damp Heat, Steady State	IEC 60068-2-78	a. 40±2°C, 90 ~ 95 % RH, 1344 hrs b. 40±2°C, 90 ~ 95 % RH, at 10%Vdc, 1344 hrs	$ \Delta V_{1mA}/V_{1mA} \leq 10\%$ No visible damage Insulation Resistance ≥ 100MΩ															
Rapid Change of Temperature	IEC 60068-2-14	The conditions shown below shall be repeated 5 cycles <table border="1"> <thead> <tr> <th>Step</th> <th>Temperature (°C)</th> <th>Period (minutes)</th> </tr> </thead> <tbody> <tr> <td>1</td> <td>-40±3</td> <td>30±3</td> </tr> <tr> <td>2</td> <td>Room temperature</td> <td>5±3</td> </tr> <tr> <td>3</td> <td>85±2</td> <td>30±3</td> </tr> <tr> <td>4</td> <td>Room temperature</td> <td>5±3</td> </tr> </tbody> </table>	Step	Temperature (°C)	Period (minutes)	1	-40±3	30±3	2	Room temperature	5±3	3	85±2	30±3	4	Room temperature	5±3	$ \Delta V_{1mA}/V_{1mA} \leq 5\%$ No visible damage
Step	Temperature (°C)	Period (minutes)																
1	-40±3	30±3																
2	Room temperature	5±3																
3	85±2	30±3																
4	Room temperature	5±3																
High Temp. Load	MIL-STD-202 Method 108	85±2°C , 1000±24 hrs at V _{DC} or V _{rms} (Max. Continuous Voltage)	$ \Delta V_{1mA}/V_{1mA} \leq 10\%$ No visible damage															
8/20μs Surge Life	IEC 61051-1	8/20μs waveform, 10 surge currents, unipolar, interval 30 secs, amplitude corresponding to max. surge current derating curves for 20μs.	$ \Delta V_{1mA}/V_{1mA} \leq 10\%$ No visible damage															
10/1000μs Surge Life	IEC 61051-1	10/1000μs waveform, 10 surge currents, unipolar, interval 2 mins, amplitude corresponding to max. surge current derating curves for 1000μs.	$ \Delta V_{1mA}/V_{1mA} \leq 10\%$ No visible damage															
Operating Duty Cycle Test	UL 1449 3 rd	Refer to UL 1449 3 rd item 37A, the test condition is I _n (Nominal Discharge Current) 8/20μs surge current waveform for 15 times.	$ \Delta V_{1mA}/V_{1mA} \leq 10\%$ No visible damage															

Metal Oxide Varistor : TVT Series



Thermally Protected Varistor Series

■ Reliability

Item	Standard	Test Conditions / Methods	Specifications						
Limited Current Abnormal Overvoltage Test	UL 1449 3 rd	Test voltage: refer to UL 1449 3 rd Table 39.1 Short current condition: <table border="1" style="margin-left: 20px;"> <thead> <tr> <th>Series</th> <th>Short Current (Isc , A)</th> </tr> </thead> <tbody> <tr> <td>TVT14</td> <td>0.125A, 0.5A, 2.5A, 5A</td> </tr> <tr> <td>TVT20</td> <td>0.5A, 2.5A, 5A, 10A</td> </tr> </tbody> </table> Each of four previously untested TVT samples to be connected to an ac power supply having an open circuit voltage equal to Uoc. The power supply is to incorporate a series variable resistor that can be adjusted to obtain the short-circuit values (Isc) respectively. The four samples are to be energized for 7 hrs, or until current to, or body temperature attain equilibrium, or until the sample becomes disconnected from the ac supply.	Series	Short Current (Isc , A)	TVT14	0.125A, 0.5A, 2.5A, 5A	TVT20	0.5A, 2.5A, 5A, 10A	No flame
Series	Short Current (Isc , A)								
TVT14	0.125A, 0.5A, 2.5A, 5A								
TVT20	0.5A, 2.5A, 5A, 10A								
Voltage Proof	IEC 61051-1	Metal balls method, 2500 Vac 1 min	No visible damage						
Varistor Voltage Temp. Coefficient	Specification Standard	$\frac{V_{1mA@85^{\circ}C} - V_{1mA@25^{\circ}C}}{V_{1mA@25^{\circ}C}} \times \frac{1}{60} \times 100\% (\% / ^{\circ}C)$ $\frac{V_{1mA@-40^{\circ}C} - V_{1mA@25^{\circ}C}}{V_{1mA@25^{\circ}C}} \times \frac{1}{65} \times 100\% (\% / ^{\circ}C)$	-0.05 ≤ T _c ≤ 0.05 (%/°C)						

■ Packaging

● Bulk Packing

Series	Quantity (pcs/bag)
TVT14	50
TVT20	25

■ Warehouse Storage Conditions of Products

- Storage Conditions:
 1. Storage temperature: -10°C ~ +40°C
 2. Relative humidity: ≤ 75%RH
 3. Keep away from corrosive atmosphere and sunlight.
- Period of Storage: 1 year