

APPROVAL SHEET



FHD ELECTRONICS CORPORATION

CUSTOMER NAME : _____

COMMODITY : PIEZO TRANSDUCER

FHD PART NO. : T161625-P4000B-S

CUSTOMER PART NO. : _____

REMARK : _____

Approved by	J.J.	Prepared by	HY Shen
-------------	------	-------------	---------

Customer Approval			
Approved		Rejected	

8104 Lynores Way, Plano, TX 75025
Tel: 469-409-2828 Cell: 408-693-5952
Email: sales@fhdmfg.com Website: www.fhdmfg.com

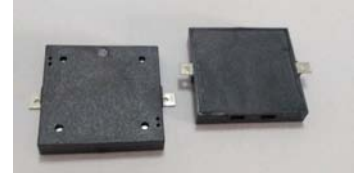
A. PART NO.: 161625-P4000B-S**B. SPECIFICATION**

No.	Item	Unit	Specification	Condition
1	Oscillation Frequency	KHz	4.0	square wave
2	Max Input Voltage	Vp-p	25 max	
3	Rated Voltage	Vp-p	9	
4	Capacitance	pF	14000±30%	at 1KHz
5	Rated Current	mA	MAX. 5	at 4KHz 50% duty Square Wave 9Vp-p
6	Sound Pressure Level	dB	MIN. 80	at 4KHz 50% duty Square Wave 9Vp-p @10cm
7	Operating Temperature	°C	-20 ~ +70	
8	Storage Temperature	°C	-40 ~ +85	
9	Dimension	mm	16 x 16 x H2.5	See appearance drawing
10	Weight (MAX)	gram	1.0	
11	Housing Material		LCP (Black)	
12	Environmental Protection Regulation		RoHS	

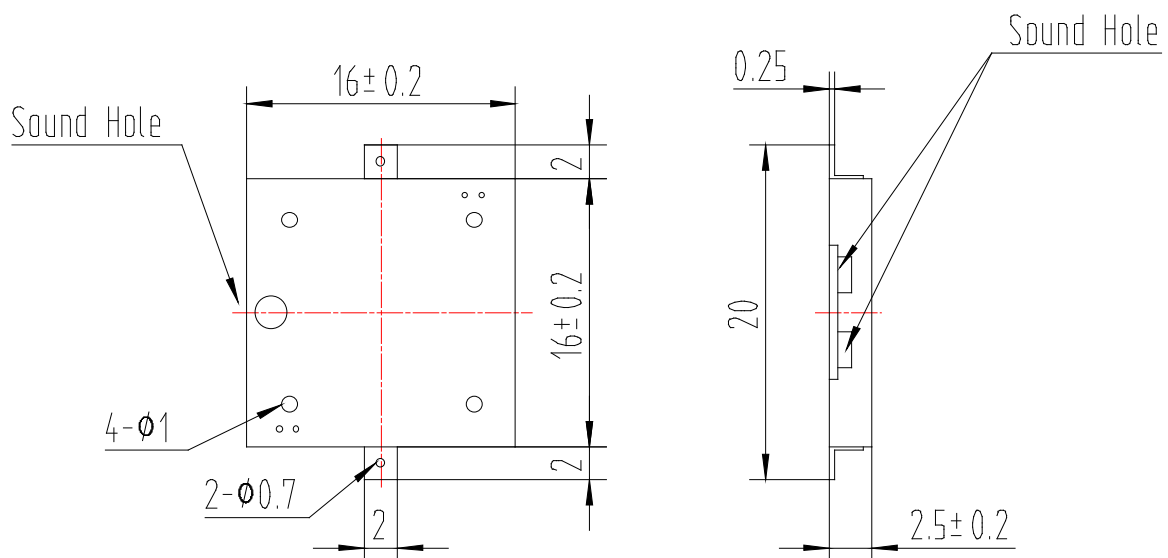
C. APPEARANCE DRAWING

*Unit: mm; Tolerance: ± 0.5 mm Except Specified

*Terminal plate: 2 soldering pads; Tin plating Brass

D. TEST METHOD

Standard Measurement Conditions: Temperature:25±2°C Humidity:45-65%

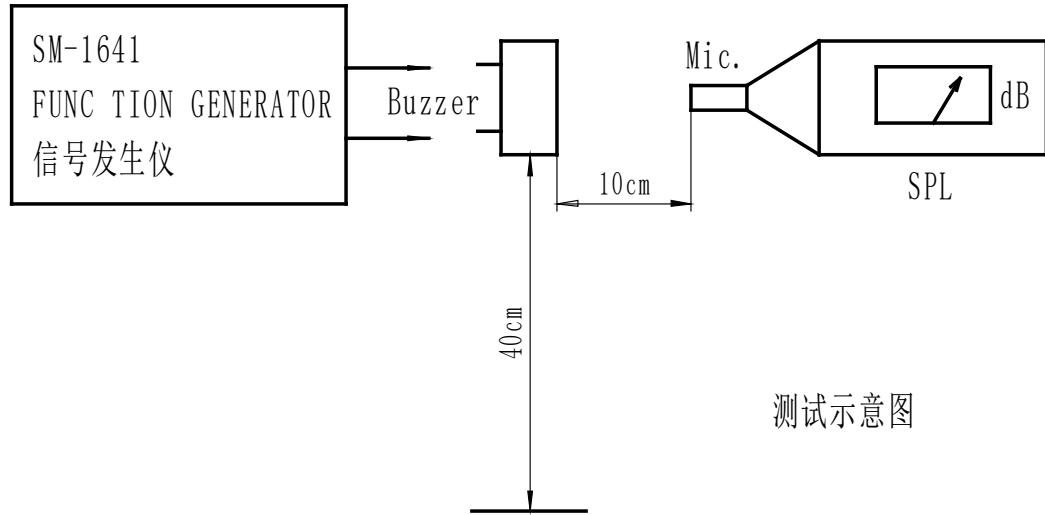

测试示意图

E. TYPICAL FREQUENCY RESPONSE CURVE

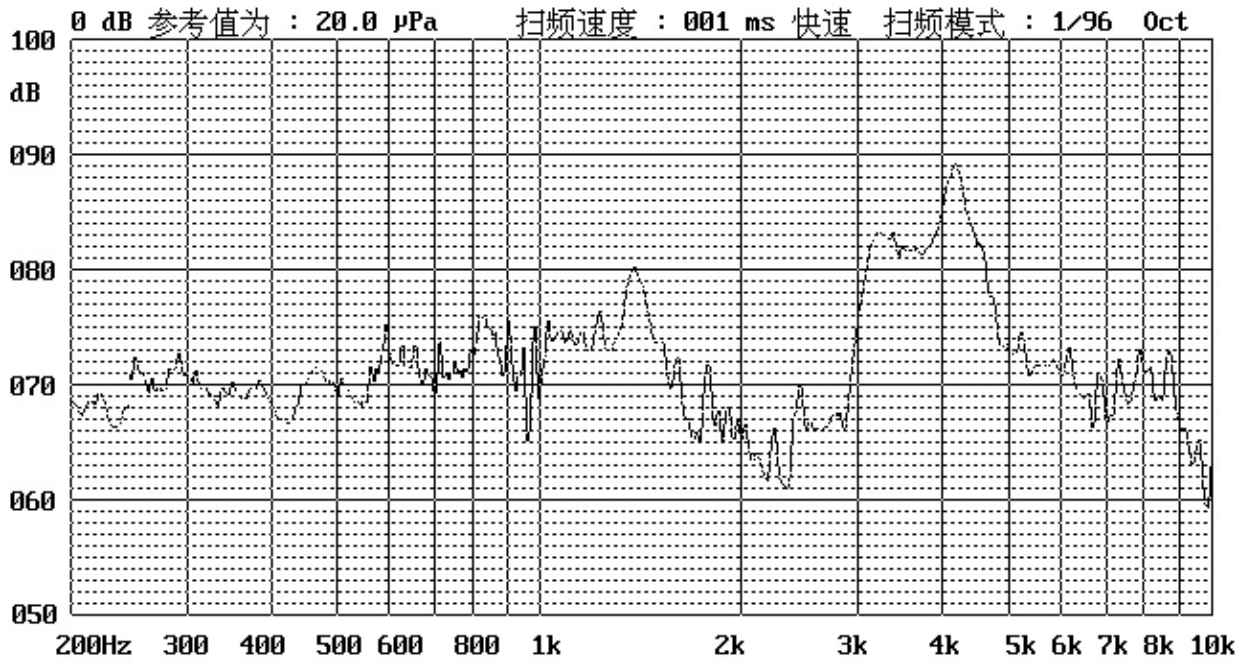

9Vp-p 50% duty Square wave,10cm

F. LOT NUMBER NOMINATION

XX X XX

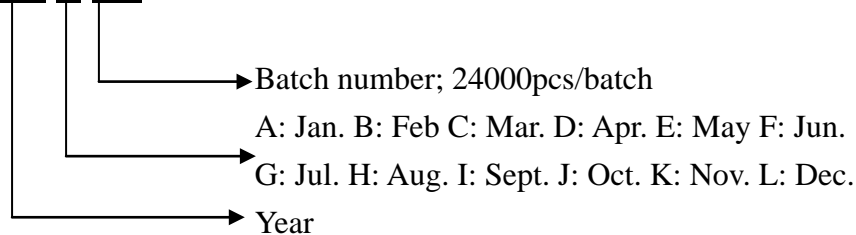

G. RELIABILITY TEST

After any following tests the part shall meet specifications without any degradation in appearance and performance except SPL. SPL shall not deviate more than -10 dB from the initial value.

1. Ordinary Temperature Life Test

The part shall be subjected to 96 hours at $25\pm 10^{\circ}\text{C}$. Input rated voltage
 Resonant frequency, 1/2 duty Square wave.

2. High Temperature Test

The part shall be capable of withstanding a storage temperature of $+85^{\circ}\text{C}$ for 96 hours.

3. Low Temperature Test

The part shall be capable of withstanding a storage temperature of -40°C for 96 hours.

4. Humidity Test

Temperature: $+40^{\circ}\text{C}\pm 3^{\circ}\text{C}$ Relative Humidity: 90% ~ 95% Duration: 48 hours and expose to room temperature for 6 hours

5. Temperature Shock Test

Temperature: 60°C /1hour \rightarrow 25°C /3hours \rightarrow 20°C /1hour \rightarrow 25°C /3hours (1 cycle)
 Total cycle: 10 cycles

6. Drop Test

Standard Packaging From 75cm (Drop on hard wood or board of 5cm thick, three sides, six plain.)

7. Vibration Test

Vibration: 1000cycles /min. Amplitude: 1.5mm, Duration: 1 hour in each 3 axes

8. Reflow Test

Use recommendable reflow soldering condition (as shown in H.1)

- (1) No abnormality should be found after reflow
- (2) Good soldering to meet soldering requirements

Note:

As this product is not protected from foreign material entering, please make sure that any foreign materials (e.g. magnetic powder, washing solvent, flux, corrosive gas) do not enter this product in your production processes. The functional degradation (e.g. SPL down) may occur if foreign material enter it.

H. RECOMMENDED TEMP. PROFILE FOR REFLOW OVEN

1. Reflow soldering

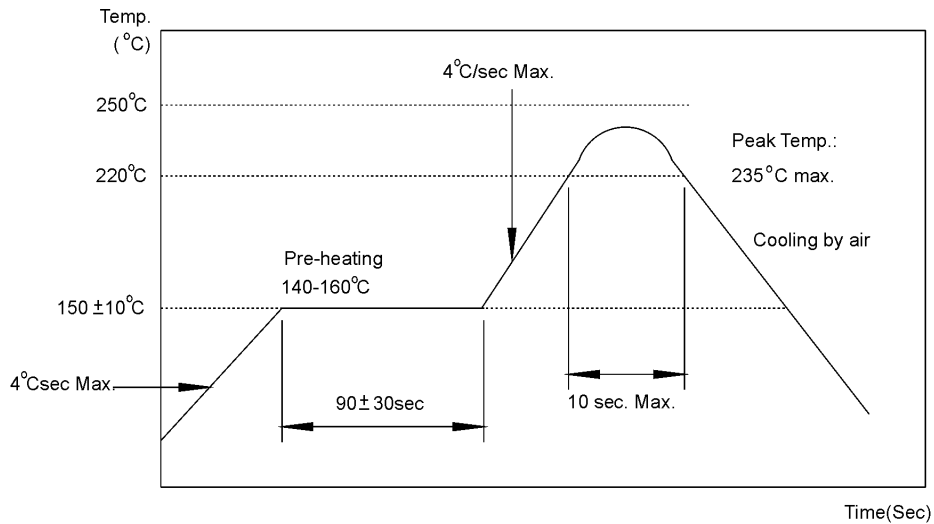

Note:

- (1) In automated mounting of the SMD sound transducers on PCB, any bending, expanding and pulling forces or shocks against the SMD sound transducers shall be kept minimum to prevent them from electrical failures and mechanical damages of the devices.
- (2) In the reflow soldering, too high soldering temperatures and too large temperature gradient such as rapid heating or cooling may cause electrical failures and mechanical damages of the devices.

2. Solder Pattern

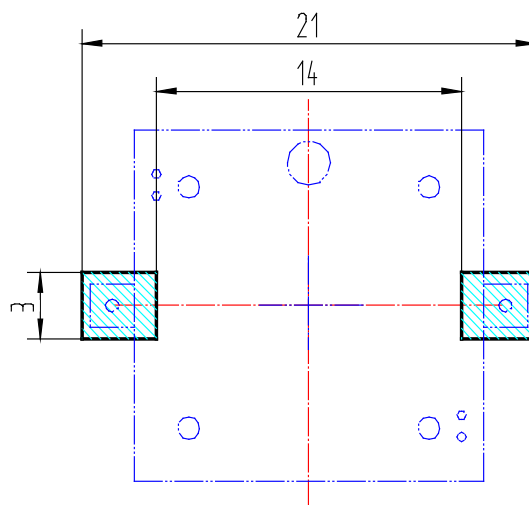

I. PACKING INFORMATION

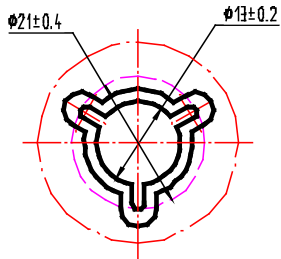
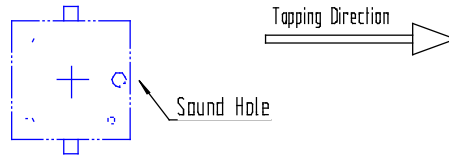
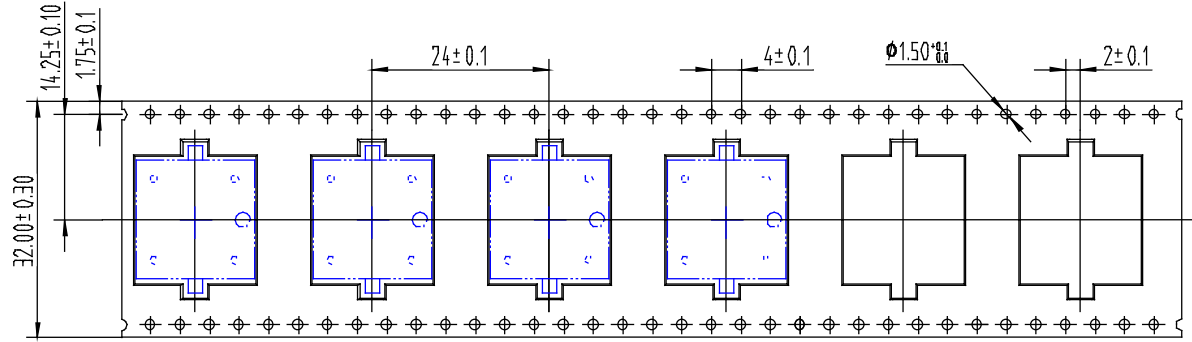

DETAIL: A
SCALE 8:1

Tapping Direction

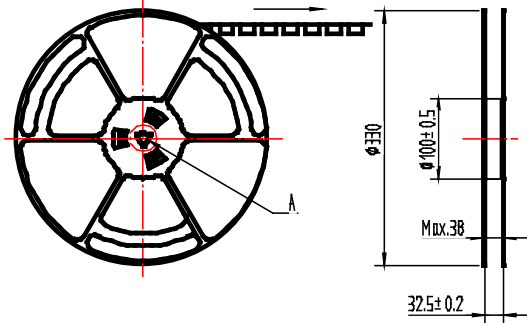

Label
P/N:
Model No.:BP1625S-4001
Qty.: 800pcs
Lot No.: XXXX

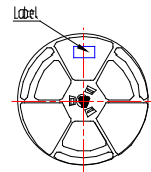

Inside box

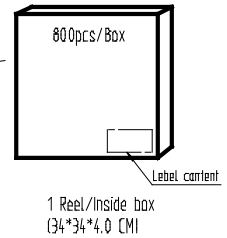
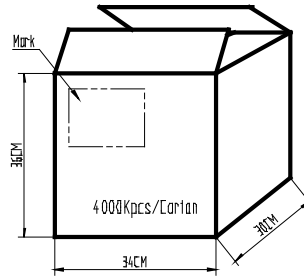

1 Reel/Inside box
(34*34*4.0 CMI)