

# APPROVAL SHEET



FHD ELECTRONICS CORPORATION

CUSTOMER NAME : \_\_\_\_\_  
COMMODITY : PIEZO INDICATOR  
FHD PART NO. : I295243-PC3500A-L  
CUSTOMER PART NO. : \_\_\_\_\_

Approved by	Y. J.	Prepared by	HY Shen
-------------	-------	-------------	---------

Customer Approval			
Approved		Rejected	

8104 Lynores Way, Plano, TX 75025  
Tel: 469-409-2828 Cell: 408-693-5952  
Email: [sales@fhdmfg.com](mailto:sales@fhdmfg.com) Website: [www.fhdmfg.com](http://www.fhdmfg.com)



## A. PART NO.: I295243-PC3500A-L

## B. SPECIFICATION

Part shall be measured under a condition (Temperature: 5~35℃, Humidity: 45%~85%R.H., Atmospheric pressure: 860 ~1060hPa) unless the standard condition (Temperature: 25±3℃, Humidity: 60±10%R.H. Atmospheric pressure: 860 ~1060hPa) is regulated to measure.



No.	Item	Unit	Specification	Condition
1	Resonant Frequency	Hz	3500 ± 500	square wave
2	Rated Voltage	VDC	12	
3	Operating Voltage	VDC	6 ~ 15	
4	Current Consumption	mA	Max. 30	At 12VDC
5	Sound Output Level	dB	Min. 95	At 12VDC @10cm
6	Operating Temperature	℃	-20 ~ +70	
7	Storage Temperature	℃	-30 ~ +80	
8	Dimension	mm	Dia. 29.5 x 24.3	See appearance drawing
9	Weight (MAX)	gram	12	
10	Housing Material		ABS ( Black )	
11	Tone		Continuous	
12	Environmental Protection Regulation		RoHS	

## B. APPEARANCE DRAWING

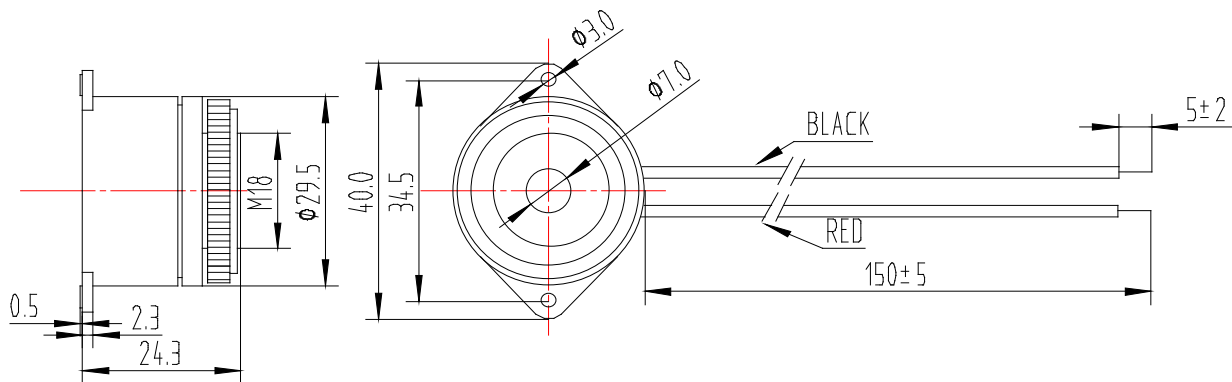

Unit: mm

Tolerance: ±0.5mm Except Specified

\*Lead wire: UL1007 28#

## D. RELIABILITY TEST

After any following tests the part shall meet specifications without any degradation in appearance and performance except SPL. SPL shall not deviate more than -5dB from the initial value

### 1. Ordinary Temperature Life Test

The part shall be subjected to 96 hours at  $25 \pm 10^\circ\text{C}$ . Input rated voltage

Resonant frequency, 1/2 duty Square wave.

### 2. High Temperature Test

The part shall be capable of withstanding a storage temperature of  $+80^\circ\text{C}$  for 96 hours.

### 3. Low Temperature Test

The part shall be capable of withstanding a storage temperature of  $30^\circ\text{C}$  for 96 hours.

### 4. Humidity Test

Temperature:  $+40^\circ\text{C} \pm 3^\circ\text{C}$  Relative Humidity: 90% ~ 95% Duration: 48 hours and expose to room temperature for 6 hours

### 5. Temperature Shock Test

Temperature:  $70^\circ\text{C}/1\text{hour} \rightarrow 25^\circ\text{C}/3\text{hours} \rightarrow 30^\circ\text{C}/1\text{hour} \rightarrow 25^\circ\text{C}/3\text{hours}$  (1 cycle)

Total cycle: 10 cycles

### 6. Drop Test

Buzzer is packed in a standard Packaging and is dropped from height 75m on a 5cm thick hard wood or board, three sides, six plain.

### 7. Vibration Test

Vibration: 1000cycles /min. Amplitude: 1.5mm, Duration: 1 hour in each 3 axes

#### Note:

As this product is not protected from foreign material entering, please make sure that any foreign materials (e.g. magnetic powder, washing solvent, flux, corrosive gas) do not enter this product in your production processes. The functional degradation (e.g. SPL down) may occur if foreign material enter it.

## E. ELECTRICAL AND ACOUSTICAL MEASURING CONDITION

### a) Recommended Setting

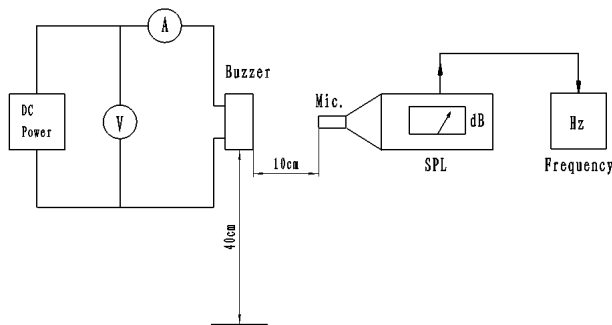

### b) Recommended Test Circuit

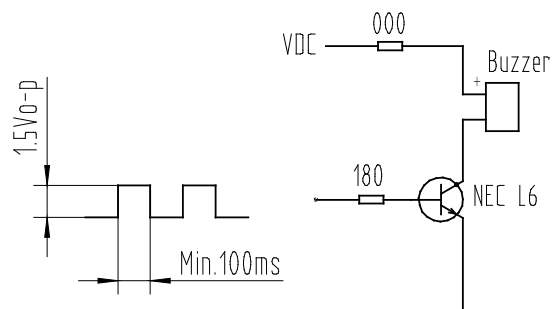

## F. PACKING INFORMATION

包装要求	1. 塑料袋包装 25 PCS/扎 75PCS/袋 料号：F6-611 2. 内箱 75PCS/盒 料号：F6-051 3. 外箱 750PCS/箱 料号：F6-003
唛头要求	内箱： 外箱：

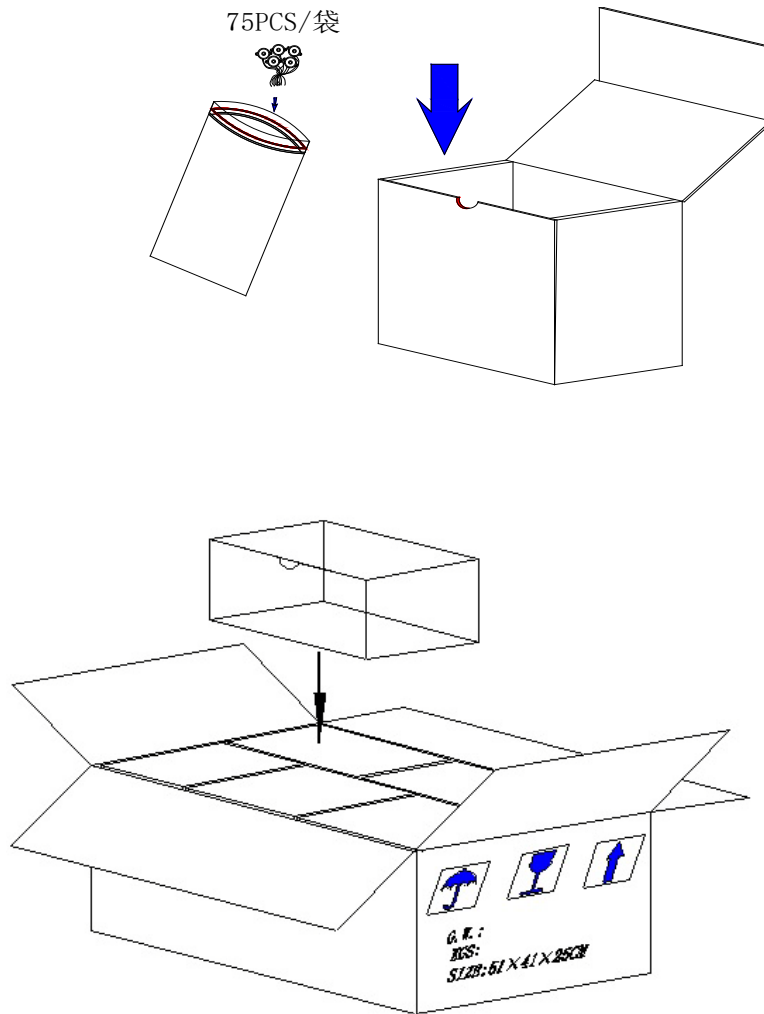

	包装名称	包装数量(pcs)	包装尺寸(mm)	图解
1	一密封袋	75	300×400	Fig. 1
2	一小盒	75	635×535	Fig. 1
3	箱子	750	500×410×250	Fig. 2