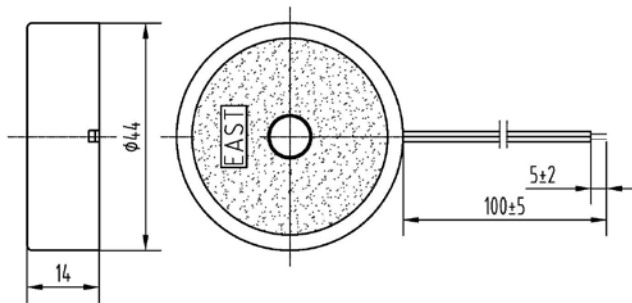

**External-driven Piezo Transducer****TFM-05B**

Rev.2

**DIMENSIONS: (Unit: mm)****FEATURES:** □

- Low Frequency
- Low Current Drain
- Light and compact

APPLICATIONS:

- Automatic Control Equipment
- Communication Equipment
- Electronic Instruments

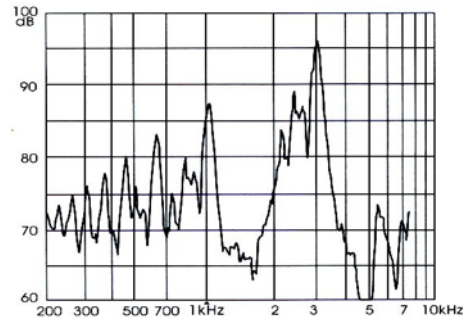
CHARACTERISTICS:**ELECTRICAL SPECIFICATIONS:**

Min. Sound Pressure Level at

1.0kHz/12V_{p-p} Square Wave/30cm.....80dB(A)

Capacitance at 120Hz.....66nF±30%

Allowable Input Voltage.....40V_{p-p}

Max. Consumption

at 1.0kHz/12V_{p-p} Square Wave.....6mA

Resonant Frequency..... 1.0±0.5kHz

Operating Temperature..... -20~+70°C

Case Material/Color.....ABS/Black

Weight..... 10g

Wire Standard.....UL1095-28AWG

PACKING INFORMATION:*(Packaging might vary without notice)*

Packing: 1000 pcs per export carton

Carton Size: 47×30.5×25 cm

G. Weight: 11.5 kgs N. Weight: 10.0 kgs

Address: No. 88. Jinhui. East Road Yinzhou, Ningbo, 315104 P. R. China

Sales Tel: +86-574-87809820(International)/87805605(Domestic)

Fax: +86-574-87803761