

**RoHS Compliant**

WP M12- 12PIN(M)

| REV | DATE     | DESCRIPTION | ECN NO. | NAME |
|-----|----------|-------------|---------|------|
| A   | 20.08.21 | PROPOSAL    |         | LWEI |

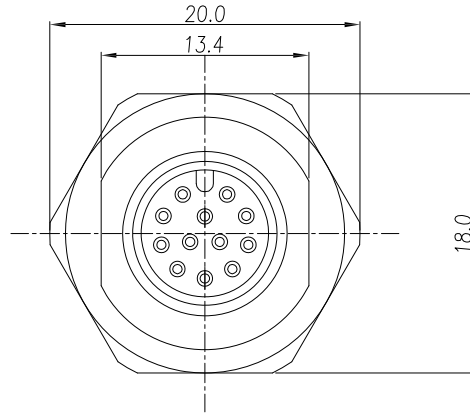
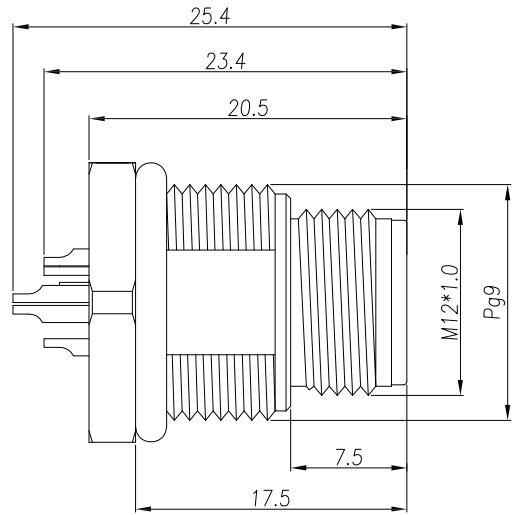

1. MATERIAL :
  - 1-1. HOUSING : PBT UL94V-0 ; COLOR : BLACK
  - 1-2. CONTACT : BRASS
  - 1-3. NUT : BRASS
  - 1-4. SHELL : BRASS
  - 1-5. O-RING: EPDM ; COLOR : BLACK
2. FINISH :
  - 2-1. CONTACT : 10u" MIN Au PLATED ON CONTACT AREA  
UNDER PLATE : NICKEL
  - 2-2. NUT : NICKEL PLATED
  - 2-3. SHELL : NICKEL PLATED
3. ELECTRICAL SPECIFICATION :
  - 3-1. Rated current : 1.5A
  - 3-2. Rated Voltage : 30V
  - 3-3. Water proof: IPX7
4. Environmental :
  - 4-1. Operation Temperature : -20°C~85°C

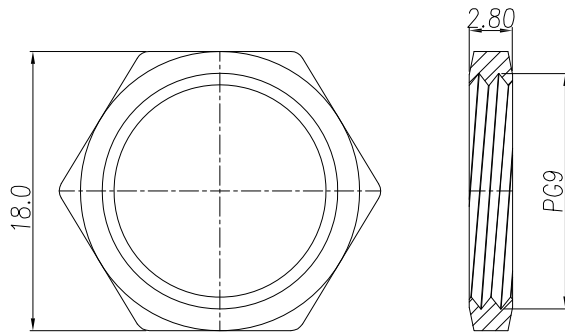

NUT

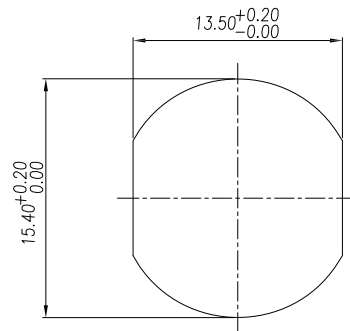

RECOMMENDPANEL CUT-OUT

CUST NO.:

PART NO.: AC3401-06150000-00

| GENERAL TOLERANCE |        | WIESON TECHNOLOGIES CO., LTD |          | STANDARD NO. |          |
|-------------------|--------|------------------------------|----------|--------------|----------|
| X.X               | =±0.20 | DRAWN BY                     | LWEI     | DRAWING SIZE | 1 : 1 A4 |
| X.XX              | =±0.15 | CHECKED BY                   | YXJ      | UNIT         | mm       |
| X.X*              | =±3'   | APPROVED BY                  | JIM      | PAGE         | 1 OF 1   |
|                   |        | SORTING NO.                  | NY (WSC) |              |          |